



Compact Scientific Digital Cameras

User Guide

CS Series Compact Scientific Cameras



Table of Contents

Chapter 1	Safety	1
	1.1. Precautions	1
	1.2. Warning Symbol Definitions	2
	1.3. Product Care	3
	1.3.1. Service	3
	1.3.2. Accessories and Customization	3
Chapter 2	Description	4
	2.1. Introduction	4
	2.2. Receiving and Unpacking	4
	2.3. Supplied Equipment	5
	2.3.1. Optional Items	5
Chapter 3	Setup & Installation	6
	3.1. Pre-Installation - USB 3.0	6
	3.2. Installing the Software	6
	3.2.1. Run the Installation File.....	6
	3.2.3. Driver Selection	6
	3.2.4. Installing 3 rd Party Software Application Support	10
	3.3. Connecting the Camera	11
	3.3.1. Multiple Camera Operation	11
	3.4. Optical and Mechanical Mounting Considerations	12
	3.4.1. Using a C-Mount Lens	12
	3.4.2. Mounting the Camera	13
	3.4.3. Using the Camera with a Cage System	14
	3.4.4. SM1 Compatible Threads.....	14
	3.5. Optical Front End	15
	3.5.1. Description of Components.....	15
	3.6. Optical Front End Procedures	16
	3.6.1. Window Removal and Replacement Procedure.....	16
	3.6.2. Re-Assembly of the Window and C-Mount Adapter and Flange Focus Adjustment	17
	3.7. Auxiliary Connector	18
	3.7.1. Pin Descriptions.....	18
	3.7.2. Signal Descriptions	18
	3.7.3. Auxiliary I/O Cable Requirements.....	19
Chapter 4	Operation	20
	4.1. Starting the Camera	20
	4.2. Camera Timing Diagrams	21
	4.2.1. Camera-Specific Timing Considerations.....	22
	4.3. Equal-Exposure Pulse (CS2100M-USB Quantalux Only)	23
	4.4. Hot Pixel Correction	24
Chapter 5	CS135MU Specifications	25
	5.1. CMOS Sensor Specifications	25

	5.2. Quantum Efficiency	25
	5.3. Imaging Specifications	25
	5.4. Example Frame Rates	26
	5.5. CS135MU Power Consumption	26
	5.6. Operating/Storage Temperatures	26
Chapter 6	CS135CU Specifications	27
	6.1. CMOS Sensor Specifications	27
	6.2. Quantum Efficiency	27
	6.3. Imaging Specifications	27
	6.4. Example Frame Rates	28
	6.5. CS135CU Power Consumption	28
	6.6. Operating/Storage Temperatures	28
Chapter 7	CS135MUN Specifications	29
	7.1. CMOS Sensor Specifications	29
	7.2. Quantum Efficiency	29
	7.3. Imaging Specifications	29
	7.4. Example Frame Rates	30
	7.5. CS135MUN Power Consumption	30
	7.6. Operating/Storage Temperatures	30
	7.7. CS135MUN AR Coated Protective Window	30
Chapter 8	CS2100M-USB Specifications	31
	8.1. sCMOS Sensor Specifications	31
	8.2. Quantum Efficiency	31
	8.3. Imaging Specifications	31
	8.4. Example Frame Rates	32
	8.5. CS2100M-USB Power Consumption	32
	8.6. Operating/Storage Temperatures	32
Chapter 9	CS235MU Specifications	33
	9.1. CMOS Sensor Specifications	33
	9.2. Quantum Efficiency	33
	9.3. Imaging Specifications	33
	9.4. Example Frame Rates	34
	9.5. CS235MU Power Consumption	34
	9.6. Operating/Storage Temperatures	34
Chapter 10	CS235CU Specifications	35
	10.1. CMOS Sensor Specifications	35

10.2. Quantum Efficiency	35
10.3. Imaging Specifications.....	35
10.4. Example Frame Rates.....	36
10.5. CS235CU Power Consumption	36
10.6. Operating/Storage Temperatures	36
Chapter 11 CS505MU Specifications	37
11.1. CMOS Sensor Specifications.....	37
11.2. Quantum Efficiency	37
11.3. Imaging Specifications.....	37
11.4. Example Frame Rates.....	38
11.5. CS505MU Power Consumption.....	38
11.6. Operating/Storage Temperatures	38
Chapter 12 CS505CU Specifications.....	39
12.1. CMOS Sensor Specifications.....	39
12.2. Quantum Efficiency	39
12.3. Imaging Specifications.....	39
12.4. Example Frame Rates.....	40
12.5. CS505CU Power Consumption	40
12.6. Operating/Storage Temperatures	40
Chapter 13 CS505MUP Specifications.....	41
13.1. CMOS Polarization Sensor Specifications	41
13.2. Quantum Efficiency	41
13.3. Imaging Specifications.....	41
13.4. Example Frame Rates.....	42
13.5. CS505MUP Power Consumption	42
13.6. Operating/Storage Temperatures	42
13.7. Extinction Ratio	42
13.8. Micropolarizer Array.....	43
13.9. Polarization Azimuth Marking.....	43
13.10. Software Compatibility.....	43
Chapter 14 CS895MU Specifications	44
14.1. CMOS Sensor Specifications.....	44
14.2. Quantum Efficiency	44
14.3. Imaging Specifications.....	44
14.4. Example Frame Rates.....	45
14.5. CS895MU Power Consumption.....	45



14.6. Operating/Storage Temperatures	45
Chapter 15 CS895CU Specifications.....	46
15.1. CMOS Sensor Specifications.....	46
15.2. Quantum Efficiency	46
15.3. Imaging Specifications.....	46
15.4. Example Frame Rates.....	47
15.5. CS895CU Power Consumption.....	47
15.6. Operating/Storage Temperatures	47
Chapter 16 Protective Glass Windows	48
16.1. Protective Glass Window Dimensions	48
16.2. AR-Coated Window Specifications.....	48
16.3. IR Filter Transmission Curve	48
Chapter 17 Mechanical Drawings	49
Chapter 18 Troubleshooting.....	50
18.1. Interface	50
18.2. Optical	50
18.3. Operational.....	51
18.4. Software	51
Chapter 19 Maintenance.....	52
19.1. Cleaning Guidelines	52
Chapter 20 Regulatory.....	54
20.1. Certifications and Compliance – CE Declaration of Conformity	55
20.2. FCC Statement.....	56
20.3. Auxiliary I/O Cable Requirements.....	56
Chapter 21 Warranty	57
21.1. General Product Warranty	57
21.2. Specific Warranties and Repairs	57
Chapter 22 Thorlabs Worldwide Contacts.....	58

Chapter 1 Safety

1.1. Precautions

Please read the instruction manual carefully before operating your Digital Camera. All statements regarding safety and technical specifications will only apply when the unit is operated correctly.

Refer to this User's Guide whenever the following symbols are encountered on the Digital Camera and Power Supply.

 **ATTENTION** 



This symbol indicates that additional information is available in this user guide.

This equipment is intended for laboratory use only and is not certified for medical applications, including but not limited to, life support situations.

Transportation and delivery may cause the Digital Camera to be warm or cool upon receipt. Please wait for the device to reach room temperature before attempting to operate.

 **WARRANTY WARNING** 

Do not open the Digital Camera. There are no user serviceable parts in this product. Opening the device will void your warranty. Any modification or servicing of this system by unqualified personnel renders Thorlabs free of any liability. This device can only be returned when packed into the complete original packaging, including all foam packing inserts. If necessary, ask for replacement packaging. Please contact Thorlabs' Technical Support at techsupport@thorlabs.com and a member of our team will be happy to assist you.

















 **CAUTION** 

This product is powered directly from the USB 3.0 port of a host computer (not included). To ensure optimal performance and the safety of the user, the host computer must use a properly grounded UL Listed or Recognized AC-DC power supply (or comparable regulatory approvals).

Dangerous voltage exists within the power supply. Do not tamper with or open the supply under any circumstances. Doing so may expose lethal voltage to personnel and will void the warranty of the computer.

1.2. Warning Symbol Definitions

Below is a list of warning symbols you may encounter in this manual or on your device.

Symbol	Description
	Direct Current
	Alternating Current
	Both Direct and Alternating Current
	Earth Ground Terminal
	Protective Conductor Terminal
	Frame or Chassis Terminal
	Equipotentiality
	On (Supply)
	Off (Supply)
	In Position of a Bi-Stable Push Control
	Out Position of a Bi-Stable Push Control
	Caution: Risk of Electric Shock
	Caution: Hot Surface
	Caution: Risk of Danger
	Warning: Laser Radiation
	Caution: Spinning Blades May Cause Harm

1.3. Product Care

Handle the camera with care during transportation and unpacking. Bumping or dropping the camera can damage the unit or lower camera performance. If the camera is mishandled during shipment, the optical components may become misaligned, which could lead to a decrease in the image quality. If this happens, the camera will need to be realigned by qualified personnel. To ensure proper care and operation of your Compact Scientific Digital Camera, please follow the handling instructions below.

- Do not store or operate in a damp, closed environment.
- Do not use solvents on or near the equipment.
- Keep away from dust, dirt, and air-borne pollutants (including cigarette smoke). The camera is not designed for outdoor use. Protect the equipment from rain, snow, and humidity.
- Do not expose to mechanical or thermal extremes. Protect the equipment from rapid variation in temperature.
- Handle all connectors with care. Do not use unnecessary force as this may damage the connectors.
- Clean using a soft, lint free cloth. Use of isopropyl alcohol is permitted, however do not immerse in any liquid or solvent.
- Clean any accessible optical surfaces with an appropriate optics grade tissue or cloth.

1.3.1. Service

Only trained and approved Thorlabs' personnel should service the camera. Please contact Thorlabs' Technical Support at techsupport@thorlabs.com and a member of our team will be happy to assist you.

1.3.2. Accessories and Customization

Although the camera is easily adapted for custom interfaces, to achieve the listed specifications, this camera should only be used with accessories provided by Thorlabs. Any modification or servicing by unqualified personnel renders the warranty null and void, leaving Thorlabs free of liability. Please contact Thorlabs for questions on customization.

All cameras are supplied with one USB3-MBA-118 cable. These cables are constructed to provide reliable data throughput at a length of 3 m. Do not replace this cable with a 3 m cable from a different vendor. The use of a shorter cable (1 m or 2 m) might be acceptable but is not guaranteed. Never use any cable that is longer than 3 m on a USB 3.0 system.

Chapter 2 Description

2.1. Introduction

Our Compact Scientific camera series consists of various monochrome and color models with USB 3.0 interfaces. All models are passively cooled and are compatible with many Thorlabs supporting products, including C-mount lenses and our 30 mm cage system. They are designed specifically to work “out of the box” in conjunction with our ThorCam software tool, and can also be operated with a variety of other imaging tools.

The model number for the **sCMOS** series  is CS2100M-USB where:

“2100” indicates 2.1 Megapixels, **M** denotes **monochrome**, and **USB** denotes a USB 3.0 interface.

The model format for the **CMOS** series  is CSxxy{M/C}U{P} where:

xxy is the number of pixels, where “xx” is the multiplier and “y” is the exponent of 10. A value of “505” is then 50 x 10⁵ indicating 5.0 Megapixels, **M/C** denotes **monochrome** or **color**, **U** indicates a USB 3.0 interface, and **P** indicates a **polarization-sensitive** camera.

The cameras are bundled with the full complement of Thorlabs Scientific Imaging (TSI) software. For end-users, the ThorCam software application provides full control of the camera through an intuitive user interface, and it allows the user to acquire, pan, zoom, analyze, and save images and metadata.

For developers, TSI also offers a Software Developer’s Kit (SDK), which includes a comprehensive Application Programming Interface (API) to streamline the integration of any TSI camera into your system. After software installation, the SDK can be found in a sub-folder under C:\Program Files\Thorlabs. This is the same directory for 32- and 64-bit distributions.

This manual is a functional overview of the camera, and it is meant to be a companion to the Camera Quick Start Guide, ThorCam User Guide, and the TSI Application Programming Interface Guide. All support documentation is available at www.thorlabs.com as well as in the C:\Program Files\Thorlabs folder following the installation of ThorCam.

2.2. Receiving and Unpacking

Your camera was thoroughly tested and carefully packed at the factory. Once the camera shipment is accepted for delivery, the carrier assumes full responsibility for its safe arrival. Should you receive your shipment with any damage—concealed or apparent—please contact the carrier at once. The carrier will instruct you on how to initiate a damage claim. If a visual inspection reveals damage upon receipt, it must be noted on the freight bill or express receipt and the notation signed by the carrier’s agent. Failure to do so can result in the carrier refusing to honor the claim.

To return your camera to TSI for service, you must first contact your local Thorlabs office or distributor and request a Return Material Authorization (RMA). Returns will not be accepted without an RMA. See Chapter 21 “Warranty” for details.

2.3. Supplied Equipment

The following is a list of equipment that is supplied with your camera

Supplied Equipment	
Interface Accessories	3 Meter Long USB 3.0 Cable ¹
Accessories	SPW502 Spanner Wrench Lens Cap
Included Software	Thorlabs Camera Software and SDK Available for Download from www.thorlabs.com/software

Note 1 - All cameras are supplied with one USB3-MBA-118 cable. These cables are constructed to provide reliable data throughput at a length of 3 m. Do not replace this cable with a 3 m cable from a different vendor. The use of a shorter cable (1 m or 2 m) may be acceptable but is not guaranteed. Never use any cable that is longer than 3 m on a USB 3.0 system.

2.3.1. Optional Items

- Auxiliary I/O Patch cable – The auxiliary connector on the camera allows the user to access optional camera control and internal status signals (see Section 3.7).
Order 8050-CAB1 with either TSI-IOBOB or TSI-IOBOB2

Chapter 3 Setup & Installation

3.1. Pre-Installation - USB 3.0

Your camera will only operate when connected to a USB 3.0 “SS” (Super Speed) port on your PC. USB 2.0 ports are not supported at this time. A USB 3.0 compatible port is typically blue - but not always. Look for this symbol above the port to be sure:



If your computer does not have a USB 3.0 port, it is likely an indication that it is an older machine, and you should consult our recommended configuration. If you must use that machine, Thorlabs recommends our PCIe USB 3.0 card (Thorlabs' part number USB3-PCIE).

Recommended Installation Sequence

1. Run the software installer, follow the steps outlined in the next section.
2. Connect the camera, power will be applied when connected to a USB 3.0 port.
3. Your PC should discover the new USB device and install the necessary drivers. This may take a minute or so for the first instance.
4. Run the ThorCam application software.

3.2. Installing the Software

The Thorlabs camera software runs on Windows 7, 8.1, and 10 operating systems ONLY.

3.2.1. Run the Installation File

3.2.2. You may download the latest version of software from our webpage [ThorCam™ Software for Scientific and Compact USB Cameras](#). Choose the appropriate installation format, 32-bit or 64-bit and download the file to your host computer. Double-click the file to run the installation.

Software Designer Kits (SDKs) for Windows and Linux are also available at the same download page.

3.2.3. Driver Selection

Your camera requires a driver to be installed on your computer. After the welcome screen, acceptance of the license agreement, and entering your user information, you will be presented with a choice of drivers. Select the driver that matches the interface on your camera, in this case USB3.0. Thorlabs offers various cameras with Gigabit Ethernet or Camera Link interfaces. If you have more than one camera, and they have different interfaces, select all that apply. If you're unsure, select them all.

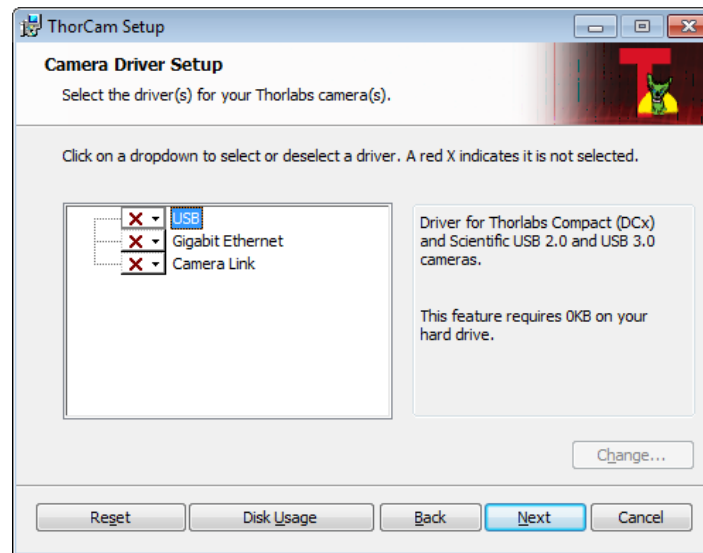

Select a driver for installation by clicking on the dropdown arrow and selecting either of the two choices; “Will be installed on local hard drive,” or “Entire feature will be installed on local hard drive.” Both choices do the same thing.

ALL compact series cameras must have the USB driver selected.

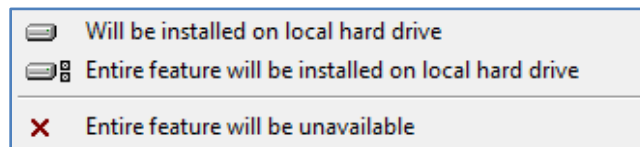

Once a driver is selected, the red X will be replaced with a hard drive icon as shown in the USB selection below.

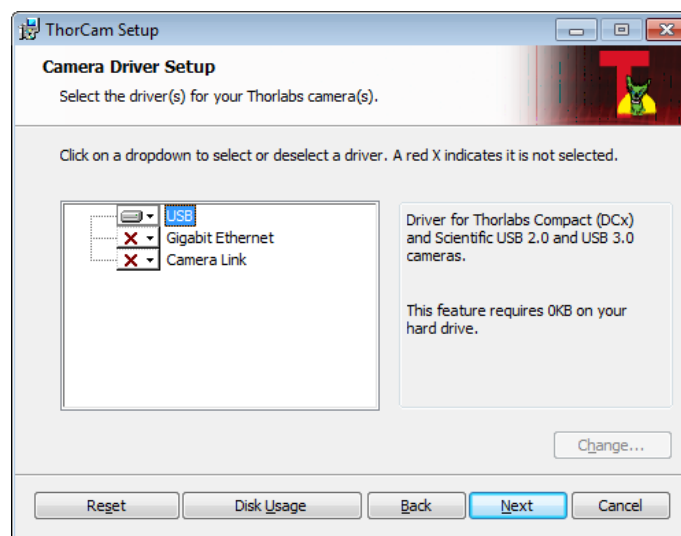

Note: Thorlabs no longer sells Camera Link models, but the software still supports them. If you are upgrading your software and have camera link cameras please select the driver during the previous step.

Click Next to proceed with the driver installation. Depending on your PC's configuration and the drivers you selected, you might encounter the additional Windows security dialogs below. Be sure to click "install" to complete the operation, otherwise the installer will "roll back" and exit.

USB Driver Installation. Click "Install". This is required for compact series cameras.

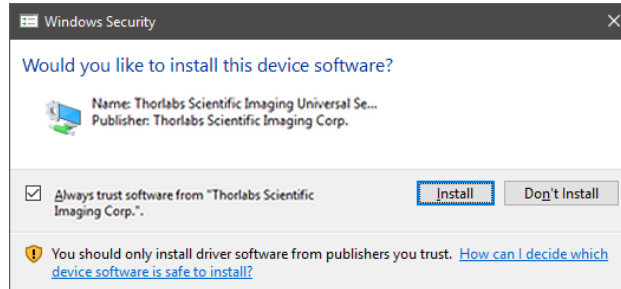

Gigabit Ethernet Driver Installation (if selected - not required for Compact Scientific cameras). Click "Install".

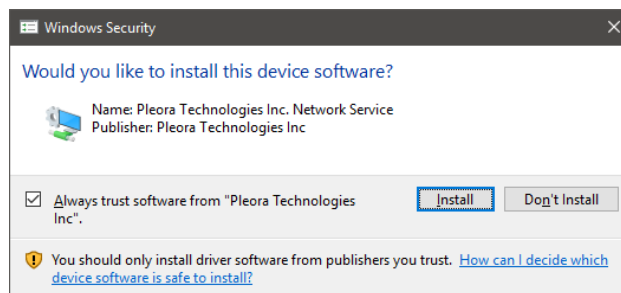

Once setup is complete, you may now proceed to the next section that will describe how to connect and power on your camera. When the camera is connected and powered up, you can navigate to the ThorCam Imaging Software as shown below:

“Start” → “All Programs” → “Thorlabs” → “Scientific Imaging” → “ThorCam”

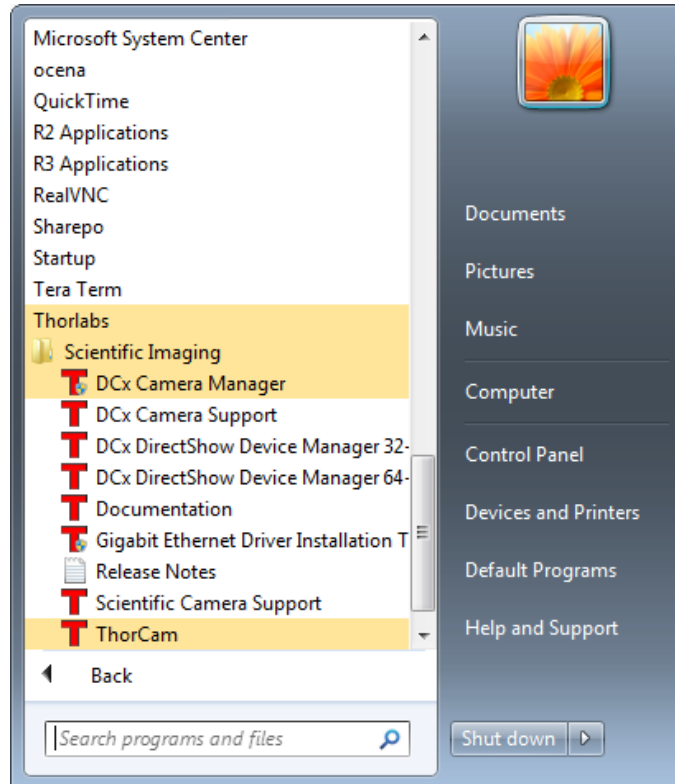

Or simply double-click on the ThorCam shortcut icon that was placed on your desktop during installation of the software:



3.2.4. Installing 3rd Party Software Application Support

After installation of Thorlabs components is complete, you have access to interfaces for select 3rd-party image analysis packages you may already have installed on your computer, such as MATLAB®.

3rd-party application software interfaces are located in Zip files in the following directory:

C:\Program Files\Thorlabs\Scientific Imaging\Scientific Camera Support

Important: Do not develop 3rd-party solutions in this directory, as they will be deleted if you update your ThorCam software.

To use the MATLAB and LabVIEW interfaces, extract from the Zip file and place in the appropriate directory on your system.

Special note for users of Micro-Manager (µManager) software: support for Thorlabs scientific cameras (excluding the CS505MUP polarization camera) is included when you run versions 1.4.14 and later. If you wish to download or update your Micro-Manager software, please visit

https://micro-manager.org/wiki/Micro-Manager_Open_Source_Microscopy_Software

Before using your camera within Micro-Manager, first make sure that your camera is properly installed and powered-on. You may run a session of ThorCam to confirm that the camera, software and drivers are properly installed. Then, shut down your ThorCam session and start a Micro-Manager session.

3.3. Connecting the Camera

To connect the camera, follow the steps below.

1. Connect the provided USB 3.0 cable¹ into the mating connector on the back of the camera. The camera end of the cable will have two thumbs screws. Make sure the connector is fully inserted, and then tighten the thumbscrews into the camera housing.
2. Connect the other end of the USB 3.0 cable into a USB 3.0 port (USB SS) on the host computer.

Note 1 - All cameras are supplied with one USB3-MBA-118 cable. These cables are constructed to provide reliable data throughput at a length of 3 m. Do not replace this cable with a 3 m cable from a different vendor. The use of a shorter cable (1 m or 2 m) may be acceptable but is not guaranteed. Never use any cable that is longer than 3 m on a USB 3.0 system.

3.3.1. Multiple Camera Operation

If multiple camera operation is required on the same computer, it is recommended that each camera uses a dedicated USB 3.0 port. Do not use a USB 3.0 hub.

3.4. Optical and Mechanical Mounting Considerations

3.4.1. Using a C-Mount Lens

For the best results, the use of a C-mount lens that matches the optical format of the sensor's imaging area is recommended (refer to the sensor specifications starting at Chapter 5). For more information on Thorlabs C-Mount lenses, please visit www.thorlabs.com.

C-mount lenses are specified with a flange focal distance of 17.5 mm. However, there can be considerable variation in the flange focal distance among commercially available lenses.

To accommodate the variation in commercially available lenses, the camera has an adjustable flange focal range of ± 1.5 mm. A procedure to set the flange focal distance is described in the next section.



Figure 1 Camera Shown with C-Mount Lens (Not Supplied) Using the C-Mount Adapter

3.4.2. Mounting the Camera

On most commercial microscopes, the use of a suitable adapter is recommended in order to match the optical format of the imaging area. Please note that some commercial 1X adapters may under fill the imaging area, leading to vignetting of the image.

The adjustable flange focus may also be used to parfocalize a microscope, as described in Section 3.6 using the adjustment wrench provided with the camera.

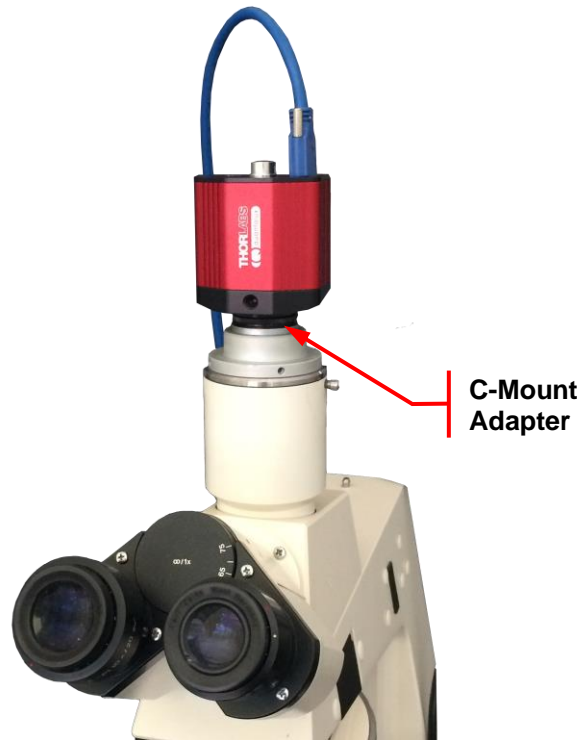

Figure 2 Camera Shown on Microscope Using C-Mount Adapter

Two 1/4"-20 tapped holes are provided, one on each side of the housing. These may be used with tripods or other optical mounting devices. These 1/4"-20 tapped holes are compatible with Thorlabs $\text{\O}1/2$ " posts. For more information on Thorlabs $\text{\O}1/2$ " posts, please visit www.thorlabs.com.



Figure 3 Arrow Indicates One of the Two 1/4"-20 Tapped Holes on Camera

3.4.3. Using the Camera with a Cage System

The cameras have 4-40 tapped holes for compatibility with Thorlabs' 30 mm Cage systems.

For more information on Thorlabs' 30 mm Cage system components, please visit www.thorlabs.com.



Figure 4 Camera Shown as Part of a 30 mm Thorlabs Cage System Using Ø1" Lens Tubes

3.4.4. SM1 Compatible Threads

The included C-mount Adapter (1.000"-32) can be completely removed (See Figure 5), exposing internal SM1 (1.035"-40) threading that is directly compatible with Thorlabs Ø1" Lens Tubes (See Figure 4).

3.5. Optical Front End

The images below show the components located on the front end of the camera.

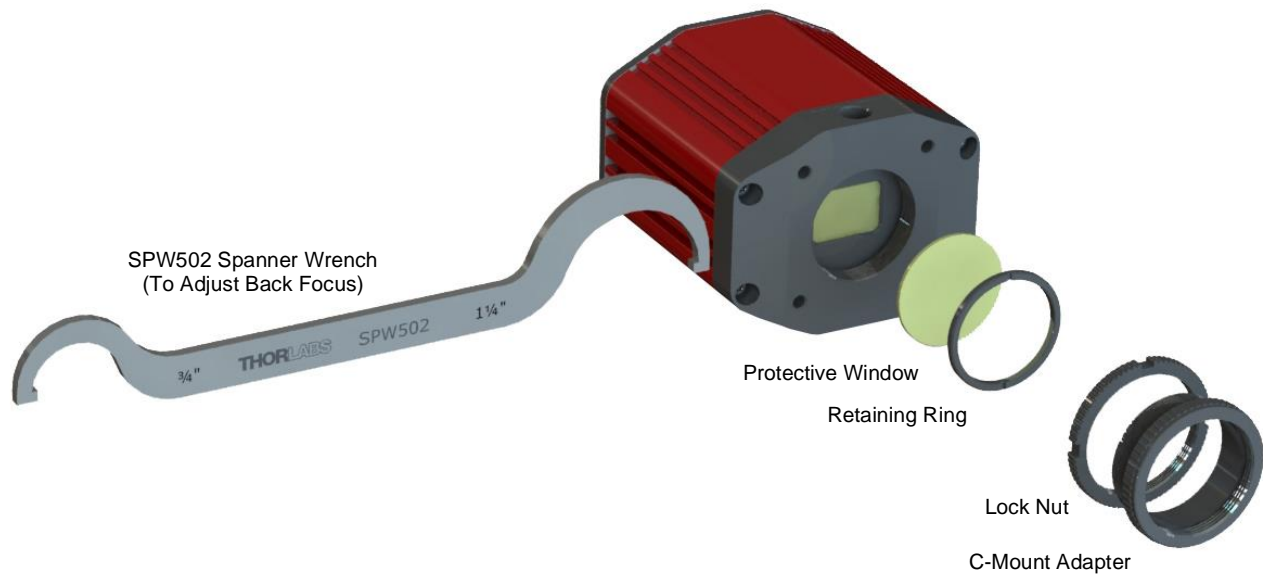

Figure 5 Exploded View of Optical and Mechanical Components

3.5.1. Description of Components

- **C-Mount Adapter:** Allows the camera to be optically coupled with standard C-mount optics, including lenses and microscope adapters.
- **Lock Nut:** Used to secure the C-mount adapter to the main camera body, while allowing adjustability of the back focus distance. An SPW502 spanner wrench is provided to loosen and tighten the lock nut (See Section 3.6.2)
- **Lens Cap (Not shown):** A protective cover that should always be installed during movement or shipment, and also when the camera is not in use.
- **Protective Window:** Unless otherwise requested, a protective glass window is installed and held in place by a retaining ring.
 - Users may, at their discretion, remove the protective glass window, or replace it with a custom optical filter. When using the C-mount adapter the maximum filter thickness is 0.050" (1.270 mm) with $\text{Ø}1"$, otherwise the maximum filter thickness is 0.173" (4.4 mm) with $\text{Ø}1"$.
 - CMOS imagers have responsivity that extends beyond the visible range, into the NIR spectral range. When installed, an NIR blocking filter cuts off light at higher wavelengths.
 - All monochrome Compact Scientific cameras are configured with an AR-coated protective window. For imaging that is limited to the visible region, users may install an NIR blocking filter in its place.
 - All color models are configured with an NIR blocking Filter as the protective window. The NIR blocking filter is installed in order to achieve realistic colors in white light.
 - See Chapter 16 for more information on both types of windows. See Section 3.6.1 for instructions related to removing and replacing the glass window.

3.6. Optical Front End Procedures

3.6.1. Window Removal and Replacement Procedure

TSI Compact Scientific cameras are provided with a protective glass window installed (See Section 3.5.1).

The optical front end is designed to accommodate standard $\varnothing 1"$ windows. Users may, at their discretion, operate the camera without any glass installed, or install custom filters in front of the sensor. The maximum filter thickness when using the C-mount adapter is 0.050" (1.270 mm). With the C-mount adapter removed the maximum filter thickness is 0.173" (4.4 mm). See Chapter 16 for more information on both types of windows.

Note: If no glass is installed, dust and debris may collect on the sensor faceplate. Care must be taken when cleaning a sensor faceplate to avoid damage to the sensor. Please use every precaution to avoid contact with the sensor faceplate and to keep the camera securely mounted to the optical system or capped when not in use.

Removal of the Window from the Camera

1. Using the provided SPW502 spanner wrench, loosen the lock nut by turning it counter-clockwise.

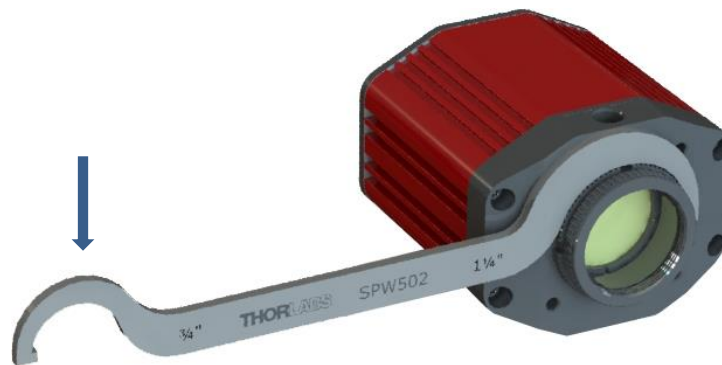

Figure 6 Loosening the C-mount Adapter

2. You can now use your fingers to turn the C-mount Adapter counter-clockwise until it is fully removed from the camera housing.
3. Using an SPW606 or equivalent tool carefully remove the SM1 retaining ring and window as shown below.

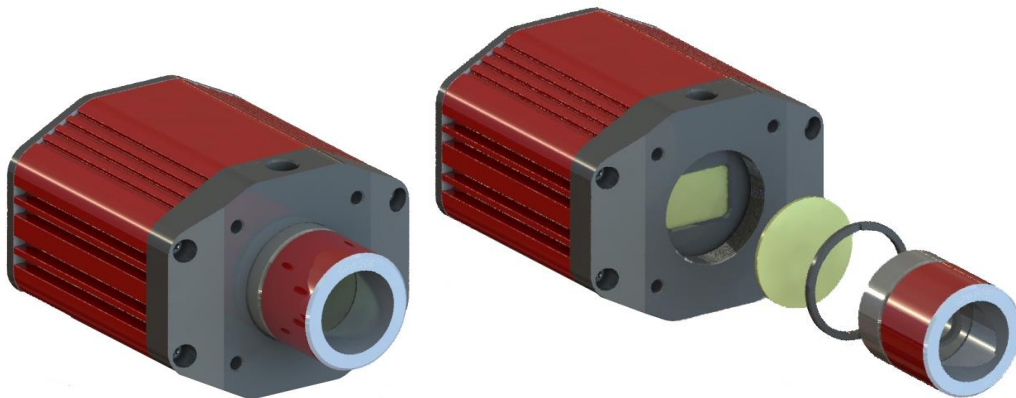

Figure 7 Removing the Window

3.6.2. Re-Assembly of the Window and C-Mount Adapter and Flange Focus Adjustment

1. Replacement of the window and C-mount adapter is done in the reverse order as shown in Section 3.6.1. **Care must be taken when handling the filter. Do NOT tighten the lock nut at this time.**
2. Install a compatible lens.
3. Power up the camera and launch the ThorCam software.
4. Make the necessary settings to acquire a live streaming image.
5. Point the camera at an object a sufficient distance away to be considered at infinity.
6. Set the Camera Lens Focus to ∞ infinity.
7. Adjust the Camera Lens Iris to obtain a viewable image.
8. Adjust the C-mount adapter ring on the camera until the image is at the best focus.
9. When the image is in sharp focus, the lens "Back Focus" is properly set.
10. Tighten the Lock Ring using the SPW502 wrench to secure the setting.

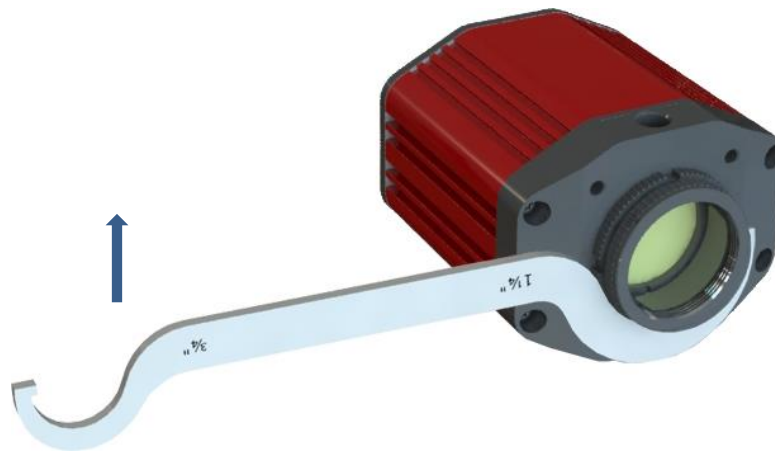

Figure 8 Tightening the Adjustable C-mount Adapter

Note: To obtain parfocality on a microscope installation with trinocular lenses, ensure that the camera port of the microscope is screwed into the lens adapter but with the knurled Lock Ring loosened. Move the assembly until the camera image and the images viewed through the oculars are simultaneously in focus. Tighten the Lock Ring using the SPW502 wrench to secure the setting.

3.7. Auxiliary Connector

The auxiliary connector on the camera allows the user to access optional camera control and internal status signals.

3.7.1. Pin Descriptions

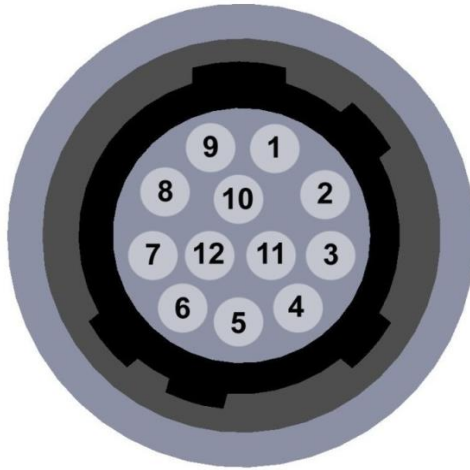

Figure 9 Illustration of the Auxiliary Connector on the Rear of the Camera

Pin Descriptions	
Pin #	Signal
1	Ground
2	Ground
3	Ground
4	LVTTTL STROBE_OUT / EEP
5	LVTTTL TRIGGER_IN
6	LVTTTL LVAL_OUT
7	OPTO I/O_OUT STROBE
8	OPTO I/O_RTN
9	OPTO I/O_IN
10	Ground
11	Ground
12	LVTTTL FVAL_OUT

3.7.2. Signal Descriptions

- **Pins 1, 2, 3, 10, 11:** Ground. This is the electrical ground for the camera TTL signals.
- **Pin 4, STROBE_OUT (Output):** STROBE_OUT is an LVTTTL output that is high during the actual sensor exposure time when in continuous, overlapped exposure mode. STROBE_OUT is typically used to synchronize an external flash lamp or other device with the camera.
- **Pin 4 EEP Alternate Function (Output – CS2100M-USB Only):** EEP - Equal-Exposure Pulse is available when Equal-Exposure Pulse is selected in the ThorCam Settings Dialog or by other means. This signal is active from the time when rolling reset is complete to the time when rolling readout commences. The Equal Exposure Pulse is typically used to synchronize an external flash lamp or other device with the camera in order to produce uniform exposures across the entire ROI. See Section 4.3.
- **Pin 5 TRIGGER_IN (Input):** TRIGGER_IN is an LVTTTL input used to trigger exposures on the camera. Transitions can occur from the HIGH to LOW states or LOW to HIGH, as selected using the ThorCam interface. Default is Low to High. Minimum Trigger Pulse-width is 100 μ s.
- **Pin 6, LVAL_OUT (Output):** LVAL_OUT refers to “Line Valid Output.” It is an active-HIGH LVTTTL signal and is asserted during the valid pixel period on each line. It returns low during the inter-line period between each line and during the inter-frame period between each frame.
- **Pin 7, OPTO I/O_OUT (Output):** The OPTO I/O_OUT signal is an optically isolated output signal. The user must provide a pull-up resistor to an external voltage source of 2.5 V to 20 V. The pull-up resistor must limit the current into this pin to <40 mA. The default signal present on Pin 7 is the STROBE_OUT signal, which is effectively the Trigger Out signal as well. Note: The value of the user supplied pull-up resistor affects the rise and fall time of this output.
- **Pin 8, OPTO I/O_RTN:** This is the return connection for the OPTO I/O_OUT output and the OPTO I/O_IN input connections. This must be connected to the pull-up source for OPTO I/O_OUT or the driving source for the OPTO I/O_IN signals.

- **Pin 9, OPTO I/O_IN (Input):** The OPTO I/O_IN signal is an optically isolated input signal used to trigger an exposure event. The user must provide a driving source from 3.3 V to 10 V. An internal series resistor limits the current into this pin to <math><50\text{ mA}</math> @ 10 V. Minimum Trigger Pulse-width is 100 μs .
- **Pin 12, FVAL_OUT (Output):** FVAL_OUT refers to “Frame Valid Output” and is an LVTTTL output that is HIGH during active readout lines. FVAL_OUT remains high throughout the active readout and returns low between frames.

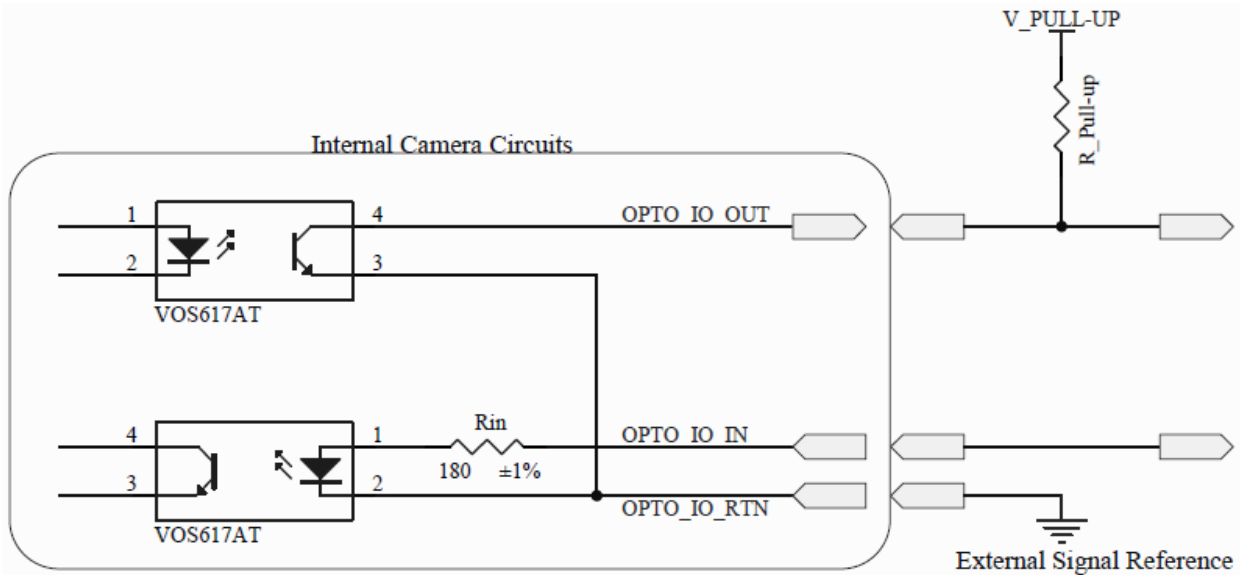

Figure 10 Internal Opto-Isolated I/O Circuits

3.7.3. Auxiliary I/O Cable Requirements

An auxiliary I/O cable may be fabricated in order to connect to the AUX I/O port of the camera. This cable is application specific in all cases due to varying lengths and functions that are used. If an Auxiliary I/O cable is to be used with this camera it must be constructed using shielded cabling in order for the camera to adhere to CE and FCC compliance. Lengths greater than 10 feet (3 m) have not been evaluated for EMC compliance. The mating connector for the rear panel connector is **HIROSE HR10-10P-12P (73)**.

A 10 foot long (3 m) auxiliary I/O cable and interconnect break-out board are available from Thorlabs allowing access to some of the I/O control functions (LVTTTL_Trigger_In, LVTTTL_LVAL_Out, LVTTTL_FVAL_Out, and LVTTTL_Strobe_Out). OPTO I/O_OUT, OPTO I/O_RTN, and OPTO I/O_IN are not supported. Order 8050-CAB1 with either TSI-IOBOB or TSI-IOBOB2, as well as the required number and style of SMA patch cables for your specific application. Order the CA28xx SMA-to-BNC series (e.g. CA2848 for 48" cable) or the CA29xx SMA-to-SMA series (CA2948 for 48" cable) as needed.

Chapter 4 Operation

The Compact Scientific series cameras can be operated using the ThorCam Imaging Software. For more details on using ThorCam please consult the ThorCam User Manual.

4.1. Starting the Camera

With the camera software installed and the camera connected as instructed (Refer to Section 3.3), the Status LED should light up solid Yellow, turning to solid Blue several seconds after power is applied. The table below details the conditions represented by the status indicator.

LED	If LED is Flashing	If LED is On	If LED is Off
Status	USB port cannot provide sufficient power to the camera	Blue: Connected to a USB 3.0 Port Green: Connected to a USB 2.0 Port Yellow: Camera has internal problem or computer USB port has malfunctioned	There is no USB Connection providing power to the camera

If you are using the ThorCam Image Acquisition Software please refer to the ThorCam User Guide, which can be accessed in the Documentation selection under the Start menu / All Programs listing for Thorlabs' products.

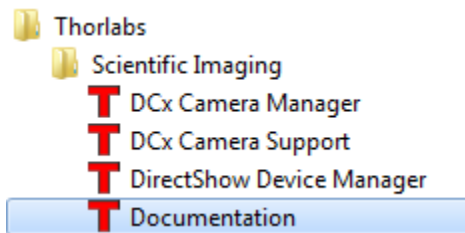

4.2. Camera Timing Diagrams

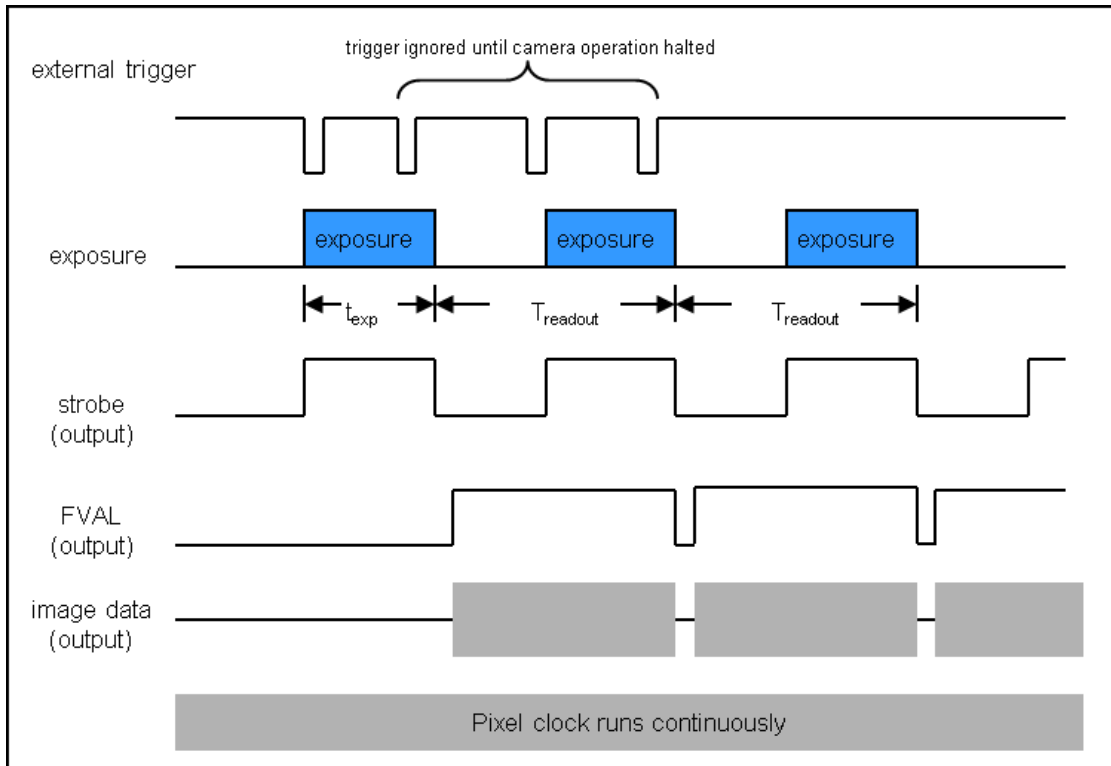

Figure 11 Timing Diagram – Standard, Frames per Trigger = 0 or > 1

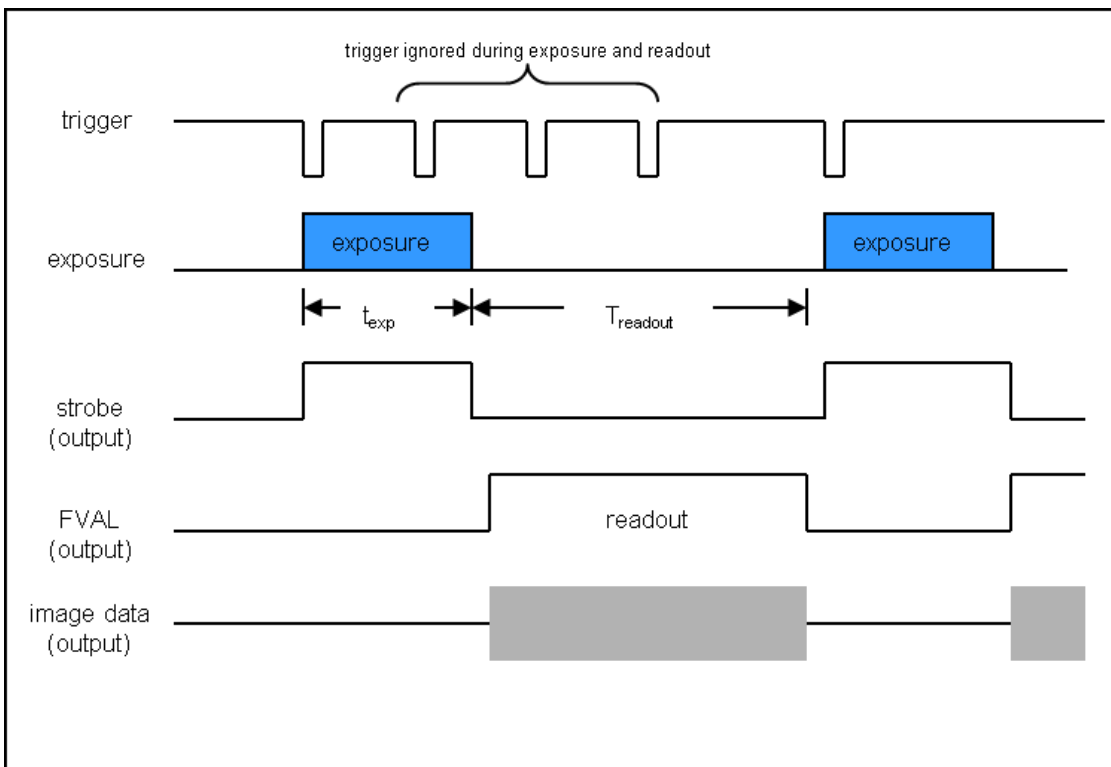

Figure 12 Timing Diagram – Standard, Frames per Trigger = 1

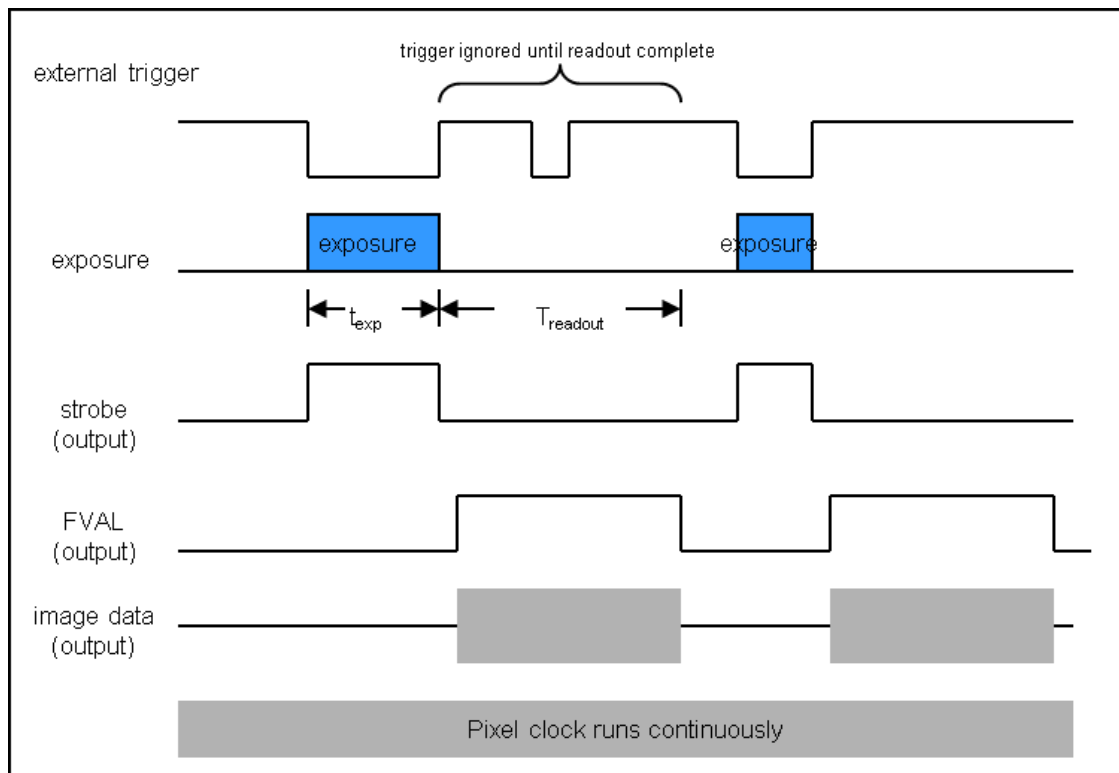

Figure 13 Timing Diagram – Bulb Mode

4.2.1. Camera-Specific Timing Considerations

Due to the general operation of our Kiralux CMOS sensor cameras, as well as typical system propagation delays, the timing relationships shown above are subject to the following considerations:

- 1) The delay from the external trigger to the start of the exposure and strobe signals is typically 270 ns for all triggered modes (standard and PDX/Bulb) for CS235, CS505, and CS895 models. For CS135 models the delay is 3.5 μ s.
- 2) For PDX/Bulb mode triggered exposures, in addition to the start delay discussed above, there is also a fixed exposure time error¹ AFTER the falling edge of the external trigger. This is inherent in the sensor operation.

It is important to note that the Strobe_Out signal includes the additional fixed exposure time error and therefore is a better representation of the actual exposure time. Our suggestion is to use the Strobe_Out signal to measure your exposure time and adjust your PDX mode trigger pulse accordingly.

Note 1 – The fixed exposure time error for the CS235 and CS505 models is 13.72 μ s. The error for the CS895 models is 14.26 μ s. For the CS135 models it is 28 μ s.

4.3. Equal-Exposure Pulse (CS2100M-USB Quantalux Only)

The Equal-Exposure Pulse (EEP) is an output signal available on the Quantalux Compact Scientific camera's I/O connector (Refer to Section 3.7). When operated from the ThorCam acquisition software, checking the Equal Exposure Pulse box in the Settings Dialog will reconfigure the Strobe_Out signal on the I/O connector to be active only after the sensor's "rolling reset" function has completed. The signal will remain active until the sensor's "rolling readout" function begins. This means that the signal is active only during the time when all of the sensor's pixels have been reset and are actively integrating. The resulting image will not show an exposure gradient typical of rolling reset sensors.

The EEP can only be produced when the exposure time is greater than the rolling reset period - defined as the reciprocal of the frame rate. Exposure time, optimization rate, and ROI all determine the final frame rate, so varying combinations of all will determine when the signal can be produced. For example, a CS2100M-USB at full frame ROI, with a Data Rate setting of 30 fps requires an exposure setting greater than ~33.3 ms for EEP to be active. Changing the ROI to 50% also changes the minimum exposure setting for an active EEP to ~16 ms.

The EEP is primarily meant to be used to control a light source that will expose a scene for a precise duration only when all pixels are integrating charge. The user must keep in mind that the exposure setting will not be the *effective* exposure produced from the external light source. A rule of thumb would be to subtract the rolling reset period from the exposure setting to arrive at an approximate *effective* exposure time.

Using the example above, a CS2100M-USB at full frame ROI, with a Data Rate setting of 30 fps requires an exposure setting greater than ~33.3 ms for EEP to be active. If you set the exposure time in the Setting window to 43.3 ms, your *effective* exposure as a result of using an external light source driven from the EEP would be ~10 ms.

The ThorCam acquisition software provides an intuitive interface for setting your desired exposure *pulse time* without having to worry about the impact of the other parameters, including the overall exposure time. ThorCam allows a minimum pulse width of 1 ms, with increments of 0.1 ms.

Be aware that the EEP has no bearing on continuously illuminated scenes, and the resulting exposure and timing relationship will be that of a normal acquisition.

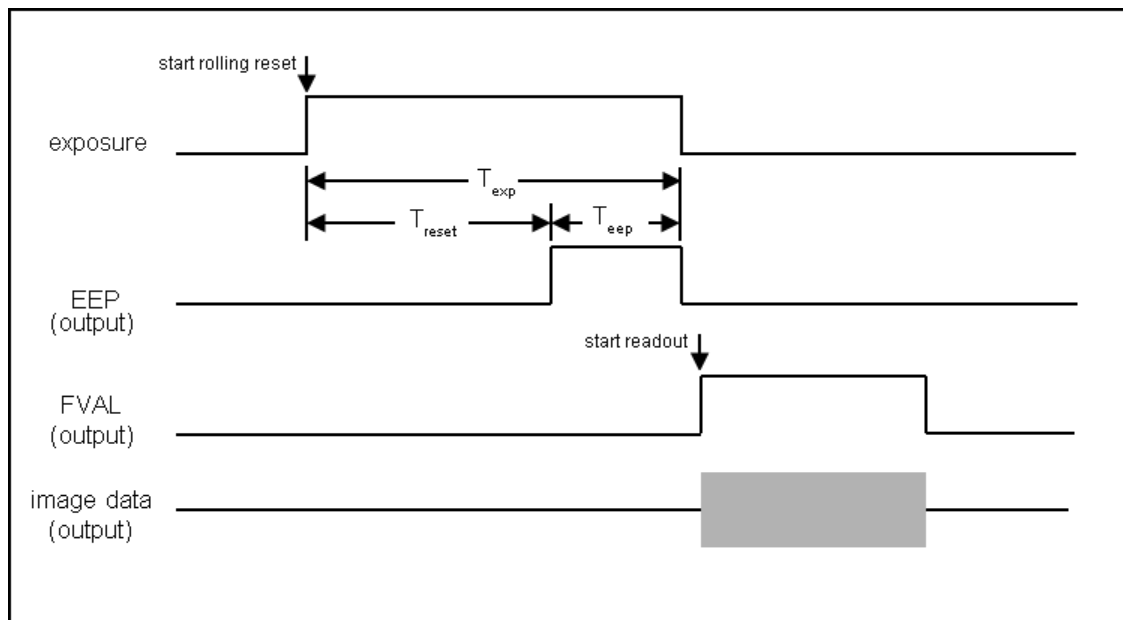

Figure 14 Timing Diagram – Equal-Exposure Pulse

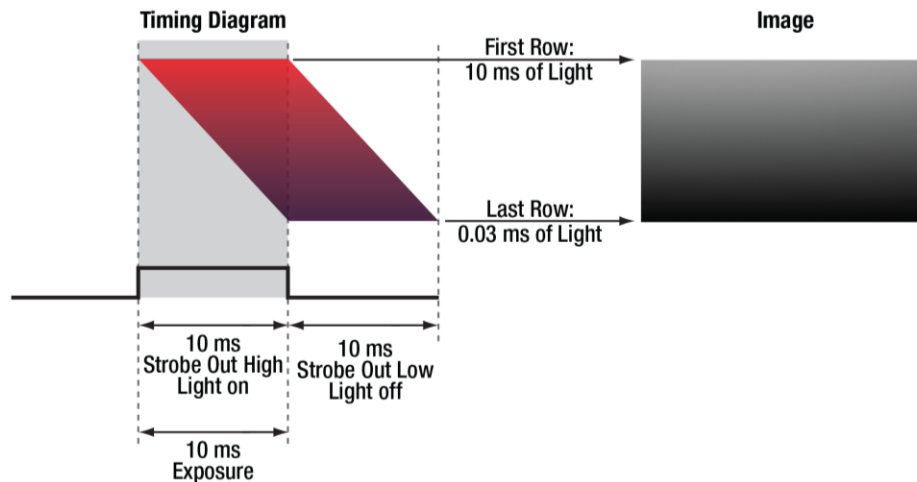

Figure 15 Timing Diagram – Strobe Driven Exposure

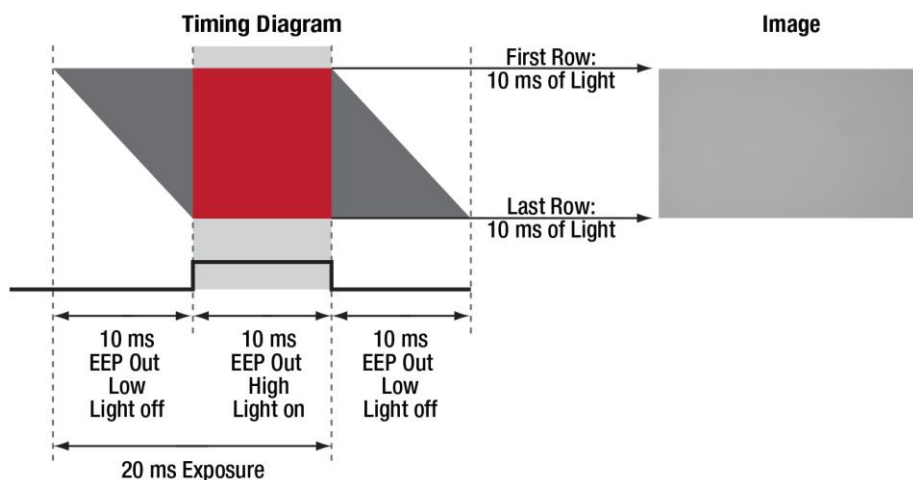

Figure 16 Timing Diagram – EEP Driven Exposure

4.4. Hot Pixel Correction

Hot Pixel Correction is a firmware function that identifies and corrects pixels that are much brighter than their surrounding pixels. Typically visible as very bright pixels regardless of the scene being imaged, these are unavoidable by-products of the CMOS and sCMOS sensor manufacturing process.

This feature can be activated by checking the **Hot Pixel Correction** check box in the ThorCam acquisition software Settings Dialog. The **Threshold** can then be adjusted using the adjacent slider or the numeric input box. The Hot Pixel Correction box can only be checked and unchecked when the camera is stopped. Once it is checked however, the Threshold adjustment can be made on a live image.

A hot pixel is identified by comparing with the mean value of the surrounding 8 pixels out of a 3x3 neighborhood. If the difference between the pixel value and the mean is larger than a specified threshold value, then this pixel is considered a hot pixel and will be replaced with the median value of those pixels in the neighborhood. As the slider is moved towards “Aggressive,” the threshold is reduced in a linear fashion. The minimum threshold value, corresponding to the upper limit, has been selected to provide users with the ability to correct hot pixels having a deviation of only a few hundred counts. At this most aggressive value, it is quite likely that image content near the maximum pixel values (full scale) will be altered by the Hot Pixel Correction algorithm. This correction is done in hardware and any images saved by the host application will only have corrected data.

This feature is available on all Compact Scientific models except CS135CU.

Chapter 5 CS135MU Specifications

5.1. CMOS Sensor Specifications

Sensor Specifications	
Sensor Type	CMOS Monochrome
Number of Active Pixels	1280 (H) x 1024 (V) (~1.3 MP)
Pixel Size	4.8 μm x 4.8 μm
Optical Format	1/2" Format (6067 μm x 4838 μm)
Peak Quantum Efficiency	59% at 550 nm
Dynamic Range	> 60 dB
Full Well Capacity	$\geq 10,000 e^-$
Shutter Type	Global

5.2. Quantum Efficiency

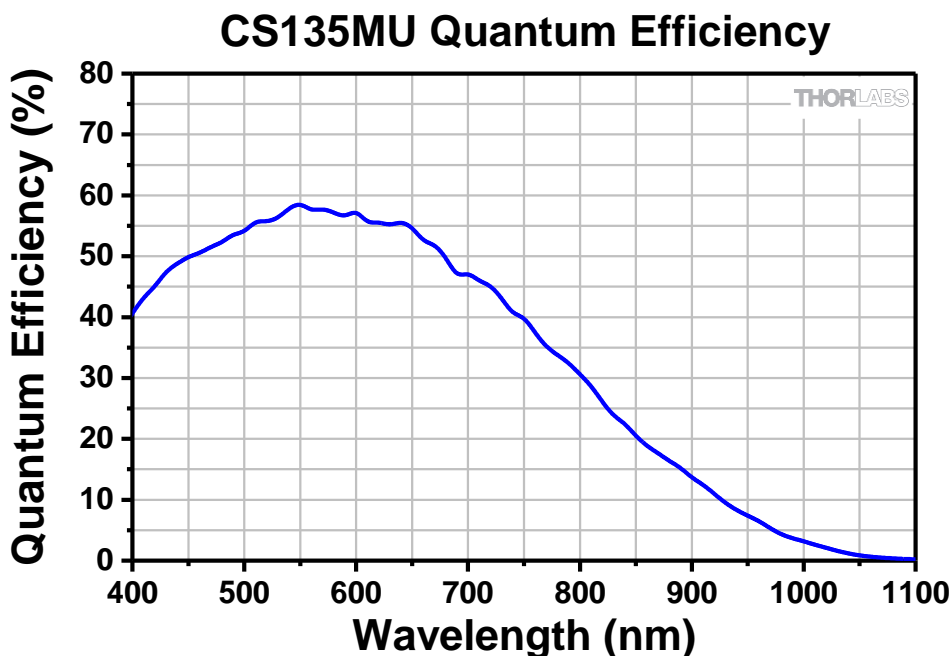

5.3. Imaging Specifications

Imaging Specifications	
Exposure Time	0.100 to 59269 ms in 0.001 ms Increments
Pixel Clock Speed	36 MHz
ADC Resolution	10 Bits
Vertical and Horizontal Hardware Binning	1 x 1 to 5 x 5
Region of Interest (Width x Height) (For Binning at 1 x 1)	16 x 2 Pixels to 1280 x 1024 Pixels, Rectangular
Read Noise	<7.0 e^- RMS
Overlapped Exposures	Frames per Trigger = Continuous Only

5.4. Example Frame Rates

ROI	Frame Rate
Full Sensor (1280 x 1024)	92.3 fps
Half Sensor (640 x 512)	309.7 fps
1/10th Sensor (128 x 102)	2303 fps
Min ROI (16 x 2)	4747 fps

~0.1 ms Exposure Time, 1 x 1 Binning,
Frames per Trigger = Continuous

5.5. CS135MU Power Consumption

3.15 W Max @ 92.3 fps Full Sensor ROI

5.6. Operating/Storage Temperatures

Operating: 10 °C to 40 °C (Non-condensing)

Storage: 0 °C to 55 °C

Chapter 6 CS135CU Specifications

6.1. CMOS Sensor Specifications

Sensor Specifications	
Sensor Type	CMOS Color
Number of Active Pixels	1280 (H) x 1024 (V) (~1.3 MP)
Pixel Size	4.8 μm x 4.8 μm
Optical Format	1/2" Format (6067 μm x 4838 μm)
Dynamic Range	> 60 dB
Full Well Capacity	$\geq 10,000 e^-$
Shutter Type	Global

6.2. Quantum Efficiency

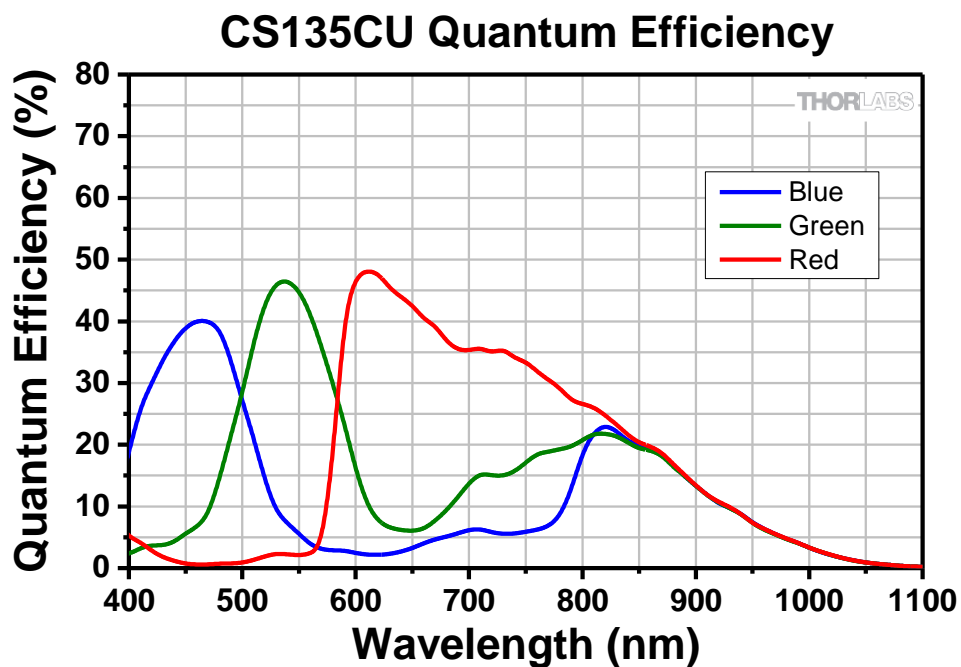

An IR-blocking filter is typically installed. This filter may be removed if NIR responsivity is desired. See Chapter 16 for specifications related to the IR-blocking filter. The Responsivity plot above is without an IR-blocking filter.

6.3. Imaging Specifications

Imaging Specifications	
Exposure Time	0.100 to 59269 ms in 0.001 ms Increments
Pixel Clock Speed	36 MHz
ADC Resolution	10 Bits
Vertical and Horizontal Hardware Binning ¹	1 x 1 to 5 x 5
Region of Interest (Width x Height) (For Binning at 1 x 1)	16 x 2 Pixels to 1280 x 1024 Pixels, Rectangular
Read Noise	<7.0 e^- RMS
Overlapped Exposures	Frames per Trigger = Continuous Only

¹ – Binning >1 x 1 only available when operating camera in unprocessed mode (monochrome).

6.4. Example Frame Rates

ROI	Frame Rate
Full Sensor (1280 x 1024)	92.3 fps
Half Sensor (640 x 512)	309.7 fps
1/10th Sensor (128 x 102)	2303 fps
Min ROI (16 x 2)	4747 fps

~0.1 ms Exposure Time, 1 x 1 Binning,
Frames per Trigger = Continuous

6.5. CS135CU Power Consumption

3.15 W Max @ 92.3 fps Full Sensor ROI

6.6. Operating/Storage Temperatures

Operating: 10 °C to 40 °C (Non-condensing)

Storage: 0 °C to 55 °C

Chapter 7 CS135MUN Specifications

7.1. CMOS Sensor Specifications

Sensor Specifications	
Sensor Type	CMOS Monochrome NIR Enhanced
Number of Active Pixels	1280 (H) x 1024 (V) (~1.3 MP)
Pixel Size	4.8 μm x 4.8 μm
Optical Format	1/2" Format (6067 μm x 4838 μm)
Peak Quantum Efficiency	60% at 600 nm
Dynamic Range	> 60 dB
Full Well Capacity	$\geq 10,000 e^-$
Shutter Type	Global

7.2. Quantum Efficiency

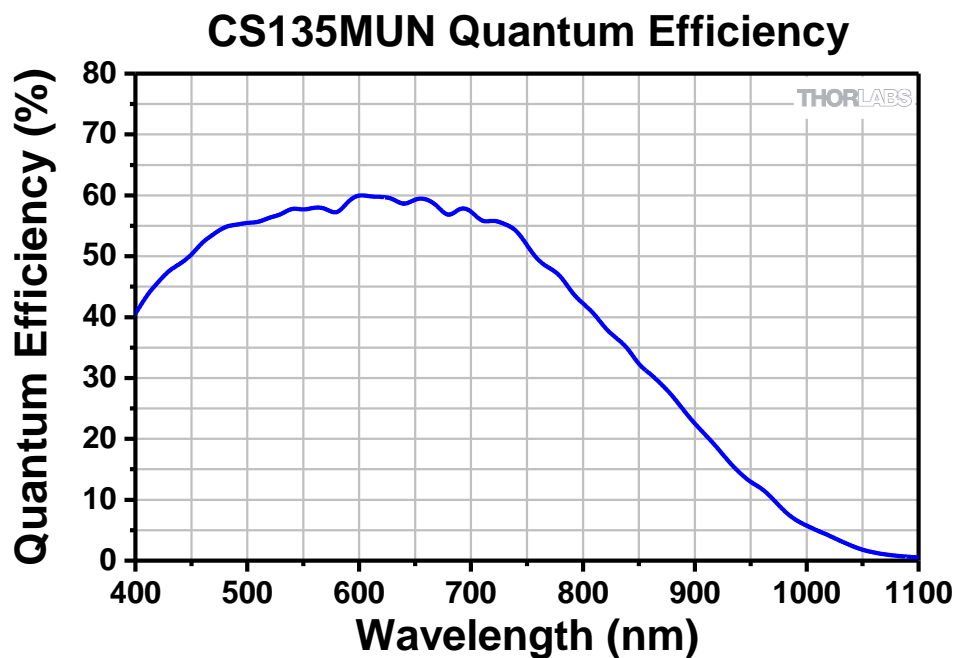

7.3. Imaging Specifications

Imaging Specifications	
Exposure Time	0.100 to 59269 ms in 0.001 ms Increments
Pixel Clock Speed	36 MHz
ADC Resolution	10 Bits
Vertical and Horizontal Hardware Binning	1 x 1 to 5 x 5
Region of Interest (Width x Height) (For Binning at 1 x 1)	16 x 2 Pixels to 1280 x 1024 Pixels, Rectangular
Read Noise	<7.0 e^- RMS
Overlapped Exposures	Frames per Trigger = Continuous Only

7.4. Example Frame Rates

ROI	Frame Rate
Full Sensor (1280 x 1024)	92.3 fps
Half Sensor (640 x 512)	309.7 fps
1/10th Sensor (128 x 102)	2303 fps
Min ROI (16 x 2)	4747 fps

~0.1 ms Exposure Time, 1 x 1 Binning,
Frames per Trigger = Continuous

7.5. CS135MUN Power Consumption

3.15 W Max @ 92.3 fps Full Sensor ROI

7.6. Operating/Storage Temperatures

Operating: 10 °C to 40 °C (Non-condensing)

Storage: 0 °C to 55 °C

7.7. CS135MUN AR Coated Protective Window

The AR (anti-reflective) coated protective window installed in all CS135MUN cameras is optimized for wavelengths compatible with the camera's NIR sensitivity. See Chapter 16 for mechanical dimensions of the window.

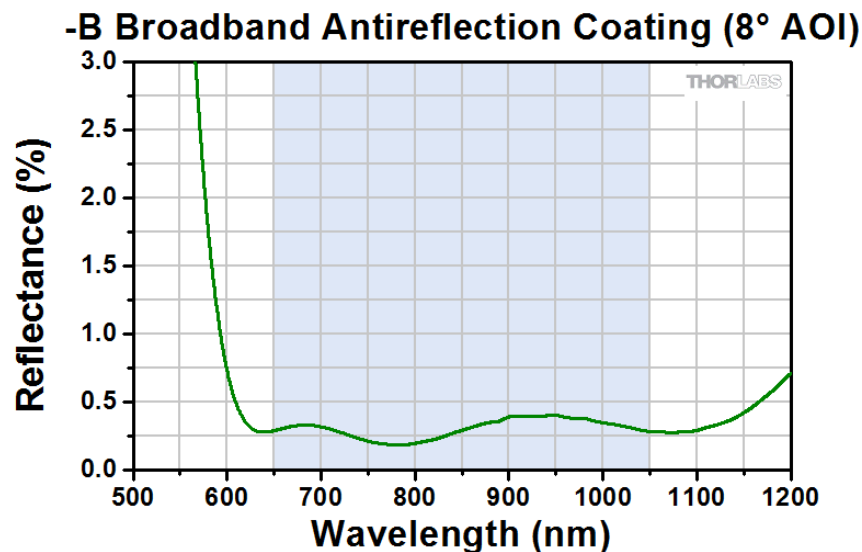

This AR coating has $R_{avg} < 0.5\%$ per surface over the 650 – 1050 nm wavelength range.

Chapter 8 CS2100M-USB Specifications

8.1. sCMOS Sensor Specifications

Sensor Specifications	
Sensor Type	sCMOS Monochrome
Number of Active Pixels	1920 (H) x 1080 (V) (~2.07 MP)
Pixel Size	5.04 μm x 5.04 μm
Optical Format	2/3" Format (9676.8 μm x 5443.2 μm)
Peak Quantum Efficiency	61% at 600 nm
Dynamic Range	Up to 87 dB
Full Well Capacity	$\geq 23,000 e^-$
Shutter Type	Rolling

8.2. Quantum Efficiency

CS2100M-USB Quantum Efficiency

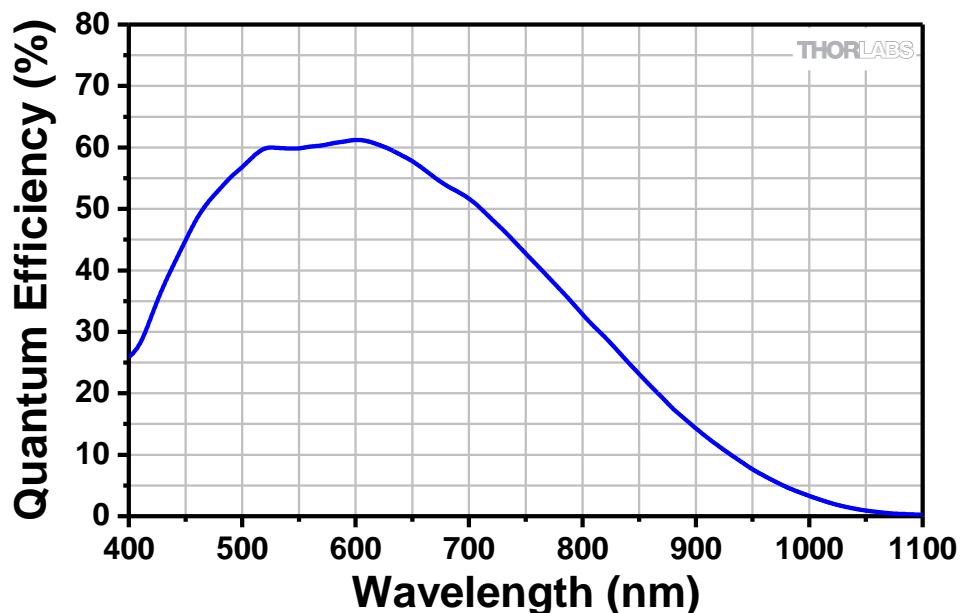

8.3. Imaging Specifications

Imaging Specifications	
Exposure Time	0.029 to 7767.2 ms in ~0.03 ms Increments
Pixel Clock Speed	74.25 MHz and 148.5 MHz
ADC Resolution	16 Bits
Vertical and Horizontal Hardware Binning	1 x 1 to 16 x 16
Region of Interest (Width x Height) (For Binning 1 x 1)	8 x 2 Pixels to 1920 x 1080 Pixels, Rectangular
Read Noise	$< 1 e^-$ Median RMS ¹ / $< 1.5 e^-$ RMS

1 - Per Sensor Manufacturer's Specification

8.4. Example Frame Rates

ROI	Frame Rate	
	L.R.N. ¹	H.F.R. ¹
Full Sensor (1920 x 1080)	30 fps	50 fps
Half Sensor, (960 x 540)	60 fps	100 fps
1/10th Sensor, (192 x 108)	300 fps	500 fps

~1 ms Exposure Time, 1 x 1 Binning,

Frames per Trigger = Continuous

1: L.R.N. is Low Read Noise and H.F.R. is High Frame Rate.

Both are Optimization modes.

8.5. CS2100M-USB Power Consumption

3.7 W Max @ 30 fps Full Sensor ROI

4.3 W Max @ 50 fps Full Sensor ROI

8.6. Operating/Storage Temperatures

Operating: 10 °C to 40 °C (Non-condensing)

Storage: 0 °C to 55 °C

Chapter 9 CS235MU Specifications

9.1. CMOS Sensor Specifications

Sensor Specifications	
Sensor Type	CMOS Monochrome
Number of Active Pixels	1920 (H) x 1200 (V) (~2.3 MP)
Pixel Size	5.86 μm x 5.86 μm
Optical Format	1/1.2" Format (11251 μm x 7032 μm)
Peak Quantum Efficiency	78% at 500 nm
Dynamic Range	Up to 75 dB
Full Well Capacity	$\geq 30,000 e^-$
Shutter Type	Global

9.2. Quantum Efficiency

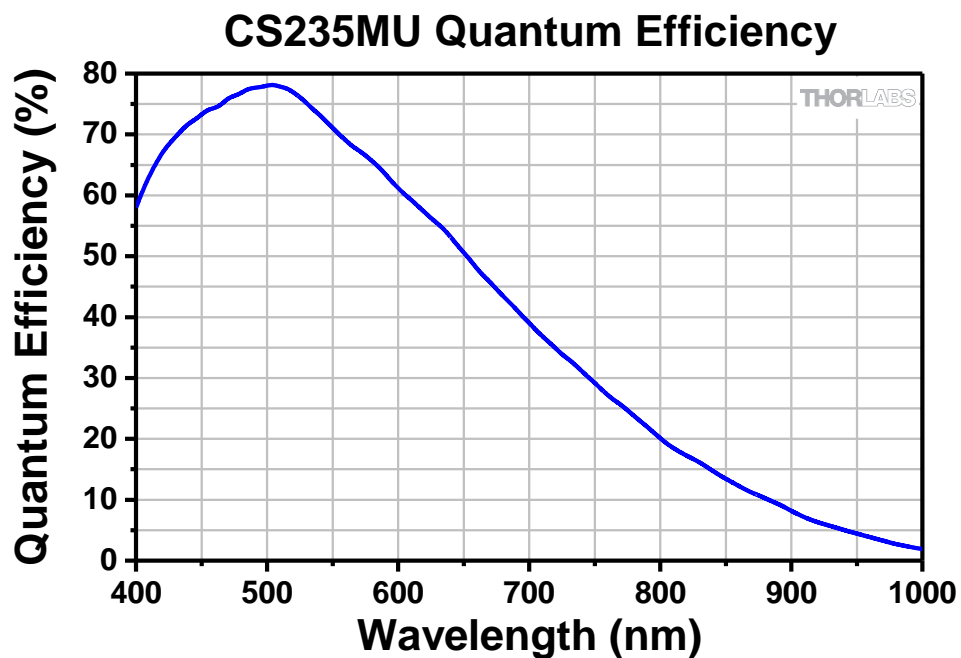

9.3. Imaging Specifications

Imaging Specifications	
Exposure Time	0.034 to 15167 ms in ~0.020 ms Increments
Pixel Clock Speed	99 MHz
ADC Resolution	12 Bits
Vertical and Horizontal Hardware Binning	1 x 1 to 16 x 16
Region of Interest (Width x Height) (For Binning at 1 x 1)	92 x 4 Pixels to 1920 x 1200 Pixels, Rectangular
Read Noise	$< 7.0 e^-$ RMS
Overlapped Exposures	Frames per Trigger = Continuous Only

9.4. Example Frame Rates

ROI	Frame Rate
Full Sensor (1920 x 1200)	39.7 fps
Half Sensor (960 x 600)	75.8 fps
1/10th Sensor (192 x 120)	277.8 fps
Min ROI (92 x 4)	781.3 fps

~1 ms Exposure Time, 1 x 1 Binning,
Frames per Trigger = Continuous

9.5. CS235MU Power Consumption

3.25 W Max @ 39.7 fps Full Sensor ROI

9.6. Operating/Storage Temperatures

Operating: 10 °C to 40 °C (Non-condensing)

Storage: 0 °C to 55 °C

Chapter 10 CS235CU Specifications

10.1. CMOS Sensor Specifications

Sensor Specifications	
Sensor Type	CMOS Color
Number of Active Pixels	1920 (H) x 1200 (V) (~2.3 MP)
Pixel Size	5.86 μm x 5.86 μm
Optical Format	1/1.2" Format (11251 μm x 7032 μm)
Dynamic Range	Up to 75 dB
Full Well Capacity	$\geq 30,000 e^-$
Shutter Type	Global

10.2. Quantum Efficiency

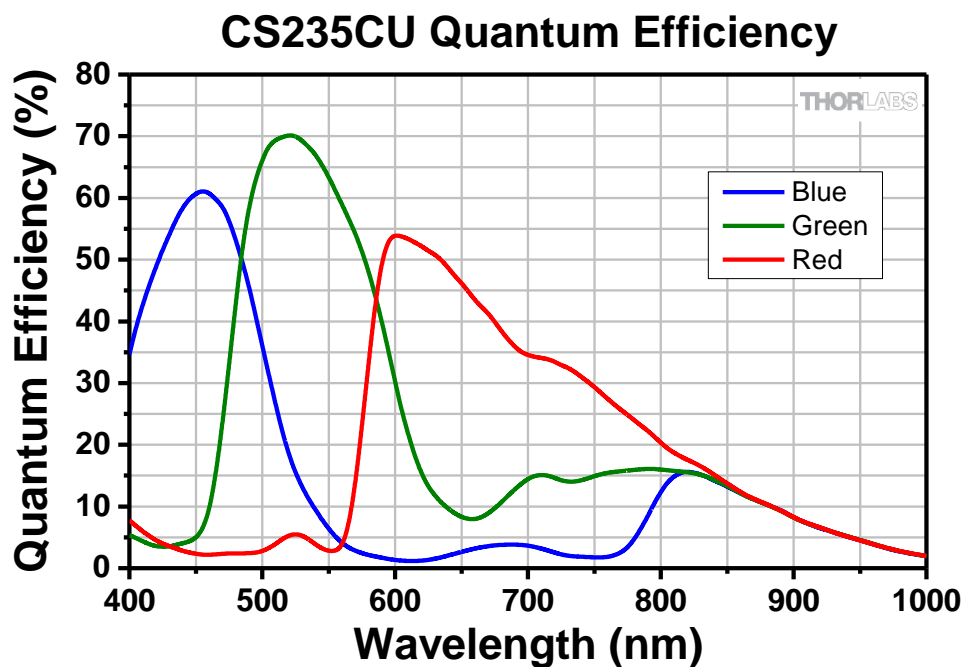

An IR-blocking filter is typically installed. This filter may be removed if NIR responsivity is desired. See Chapter 16 for specifications related to the IR-blocking filter. The Responsivity plot above is without an IR-blocking filter.

10.3. Imaging Specifications

Imaging Specifications	
Exposure Time	0.034 to 15167 ms in ~0.020 ms Increments
Pixel Clock Speed	99 MHz
ADC Resolution	12 Bits
Vertical and Horizontal Hardware Binning ¹	1 x 1 to 16 x 16
Region of Interest (Width x Height) (For Binning at 1 x 1)	92 x 4 Pixels to 1920 x 1200 Pixels, Rectangular
Read Noise	<7.0 e^- RMS
Overlapped Exposures	Frames per Trigger = Continuous Only

¹ – Binning >1 x 1 only available when operating camera in unprocessed mode (monochrome).

10.4. Example Frame Rates

ROI	Frame Rate
Full Sensor (1920 x 1200)	39.7 fps
Half Sensor (960 x 600)	75.8 fps
1/10th Sensor (192 x 120)	277.8 fps
Min ROI (92 x 4)	781.3 fps

~1 ms Exposure Time, 1 x 1 Binning,
Frames per Trigger = Continuous

10.5. CS235CU Power Consumption

3.25 W Max @ 39.7 fps Full Sensor ROI

10.6. Operating/Storage Temperatures

Operating: 10 °C to 40 °C (Non-condensing)

Storage: 0 °C to 55 °C

Chapter 11 CS505MU Specifications

11.1. CMOS Sensor Specifications

Sensor Specifications	
Sensor Type	CMOS Monochrome
Number of Active Pixels	2448 (H) x 2048 (V) (~5.01 MP)
Pixel Size	3.45 μm x 3.45 μm
Optical Format	2/3" Format (8445.6 μm x 7065.6 μm)
Peak Quantum Efficiency	72% Over 525 to 580 nm (Typical)
Dynamic Range	Up to 71 dB
Full Well Capacity	$\geq 10,000 e^-$
Shutter Type	Global

11.2. Quantum Efficiency

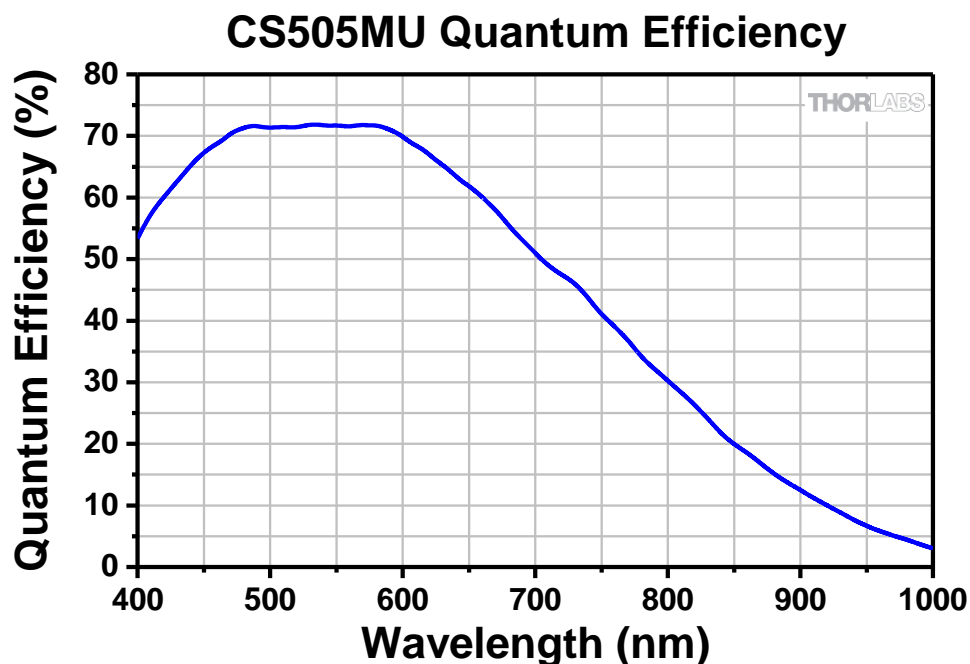

11.3. Imaging Specifications

Imaging Specifications	
Exposure Time	0.027 to 14235 ms in ~0.013 ms Increments
Pixel Clock Speed	99 MHz
ADC Resolution	12 Bits
Vertical and Horizontal Hardware Binning	1 x 1 to 16 x 16
Region of Interest (Width x Height) (For Binning at 1 x 1)	260 x 4 Pixels to 2448 x 2048 Pixels, Rectangular
Read Noise	$< 2.5 e^-$ RMS
Overlapped Exposures	Frames per Trigger = Continuous Only

11.4. Example Frame Rates

ROI	Frame Rate
Full Sensor (2448 x 2048)	35 fps
Half Sensor (1224 x 1024)	68 fps
~1/10th Sensor (260 x 208)	290 fps
Min ROI (260 x 4)	887.6 fps

~1 ms Exposure Time, 1 x 1 Binning,
Frames per Trigger = Continuous

11.5. CS505MU Power Consumption

3.6 W Max @ 35 fps Full Sensor ROI

11.6. Operating/Storage Temperatures

Operating: 10 °C to 40 °C (Non-condensing)

Storage: 0 °C to 55 °C

Chapter 12 CS505CU Specifications

12.1. CMOS Sensor Specifications

Sensor Specifications	
Sensor Type	CMOS Color
Number of Active Pixels	2448 (H) x 2048 (V) (~5.01 MP)
Pixel Size	3.45 μm x 3.45 μm
Optical Format	2/3" Format (8445.6 μm x 7065.6 μm)
Dynamic Range	Up to 71 dB
Full Well Capacity	$\geq 10,000 e^-$
Shutter Type	Global

12.2. Quantum Efficiency

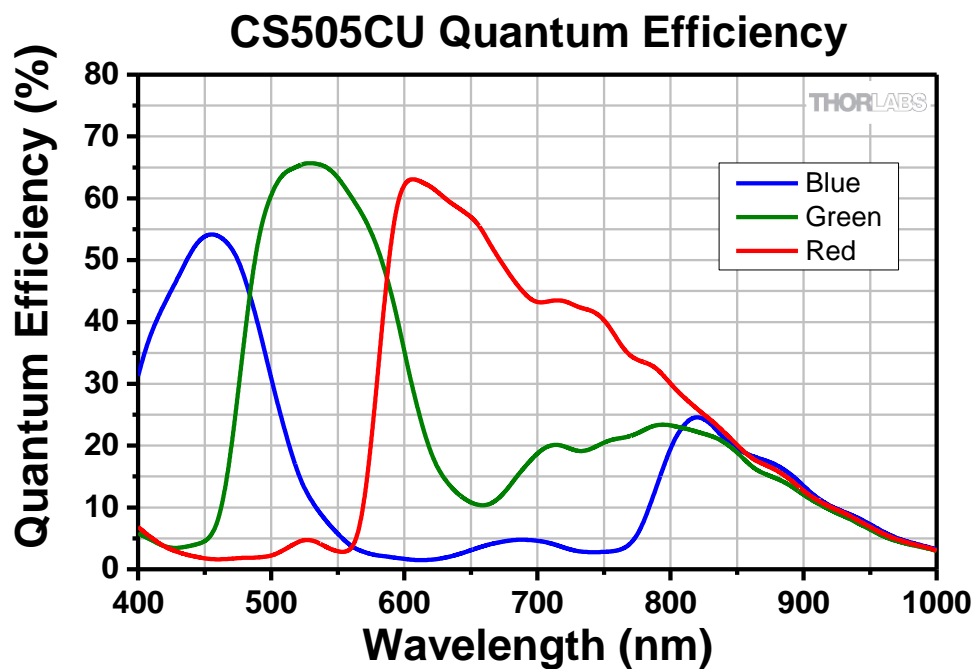

An IR-blocking filter is typically installed. This filter may be removed if NIR responsivity is desired. See Chapter 16 for specifications related to the IR-blocking filter. The Responsivity plot above is without an IR-blocking filter.

12.3. Imaging Specifications

Imaging Specifications	
Exposure Time	0.027 to 14235 ms in ~0.013 ms Increments
Pixel Clock Speed	99 MHz
ADC Resolution	12 Bits
Vertical and Horizontal Hardware Binning ¹	1 x 1 to 16 x 16
Region of Interest (Width x Height) (For Binning at 1 x 1)	260 x 4 Pixels to 2448 x 2048 Pixels, Rectangular
Read Noise	<2.5 e^- RMS
Overlapped Exposures	Frames per Trigger = Continuous only

¹ – Binning >1 x 1 only available when operating camera in unprocessed mode (monochrome).

12.4. Example Frame Rates

ROI	Frame Rate
Full Sensor (2448 x 2048)	35 fps
Half Sensor (1224 x 1024)	68 fps
~1/10th Sensor (260 x 208)	290 fps
Min ROI (260 x 4)	887.6 fps

~1 ms Exposure Time, 1 x 1 Binning,
Frames per Trigger = Continuous

12.5. CS505CU Power Consumption

3.6 W Max @ 35 fps Full Sensor ROI

12.6. Operating/Storage Temperatures

Operating: 10 °C to 40 °C (Non-condensing)

Storage: 0 °C to 55 °C

Chapter 13 CS505MUP Specifications

13.1. CMOS Polarization Sensor Specifications

Sensor Specifications	
Sensor Type	CMOS Monochrome With Micropolarizer Array
Number of Active Pixels	2448 (H) x 2048 (V) (~5.01 MP)
Pixel Size	3.45 μm x 3.45 μm
Optical Format	2/3" Format (8445.6 μm x 7065.6 μm)
Peak Quantum Efficiency	72% Over 525 to 580 nm (Typical)
Dynamic Range	Up to 71 dB
Full Well Capacity	$\geq 10,000 e^-$
Shutter Type	Global

13.2. Quantum Efficiency

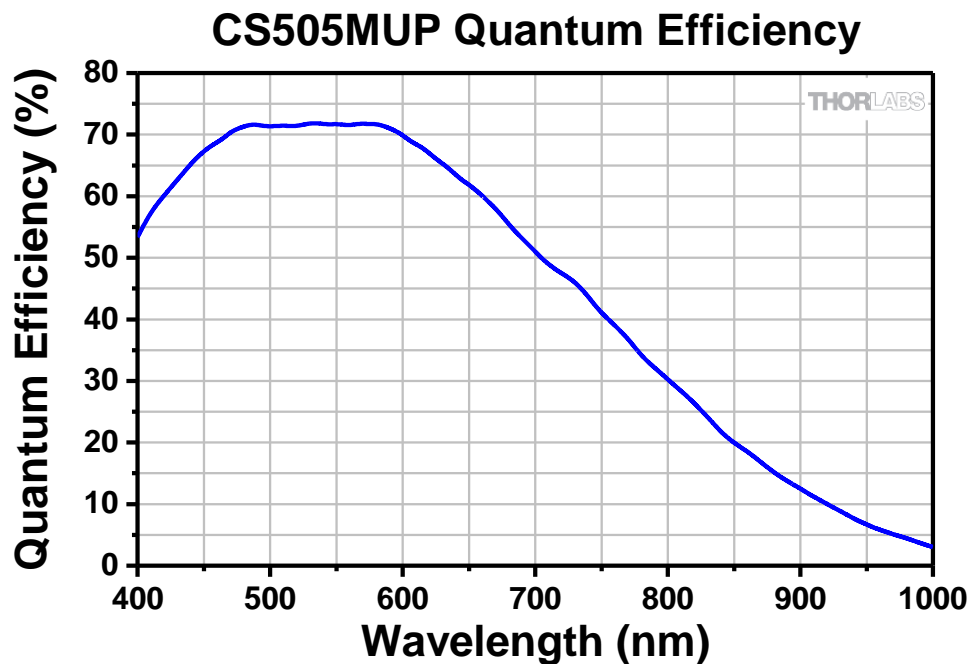

13.3. Imaging Specifications

Imaging Specifications	
Exposure Time	0.027 to 14235 ms in ~0.013 ms Increments
Pixel Clock Speed	99 MHz
ADC Resolution	12 Bits
Vertical and Horizontal Hardware Binning	1 x 1 to 16 x 16
Region of Interest (Width x Height) (For Binning at 1 x 1)	260 x 4 Pixels to 2448 x 2048 Pixels, Rectangular
Read Noise	$< 2.5 e^-$ RMS ¹
Overlapped Exposures	Frames per Trigger = Continuous Only

1 - Image Type: Unprocessed

13.4. Example Frame Rates

ROI	Frame Rate
Full Sensor (2448 x 2048)	35 fps
Half Sensor (1224 x 1024)	68 fps
~1/10th Sensor (260 x 208)	290 fps
Min ROI (260 x 4)	887.6 fps

~1 ms Exposure Time, 1 x 1 Binning,
Frames per Trigger = Continuous

13.5. CS505MUP Power Consumption

3.6 W Max @ 35 fps Full Sensor ROI

13.6. Operating/Storage Temperatures

Operating: 10 °C to 40 °C (Non-condensing)

Storage: 0 °C to 55 °C

13.7. Extinction Ratio

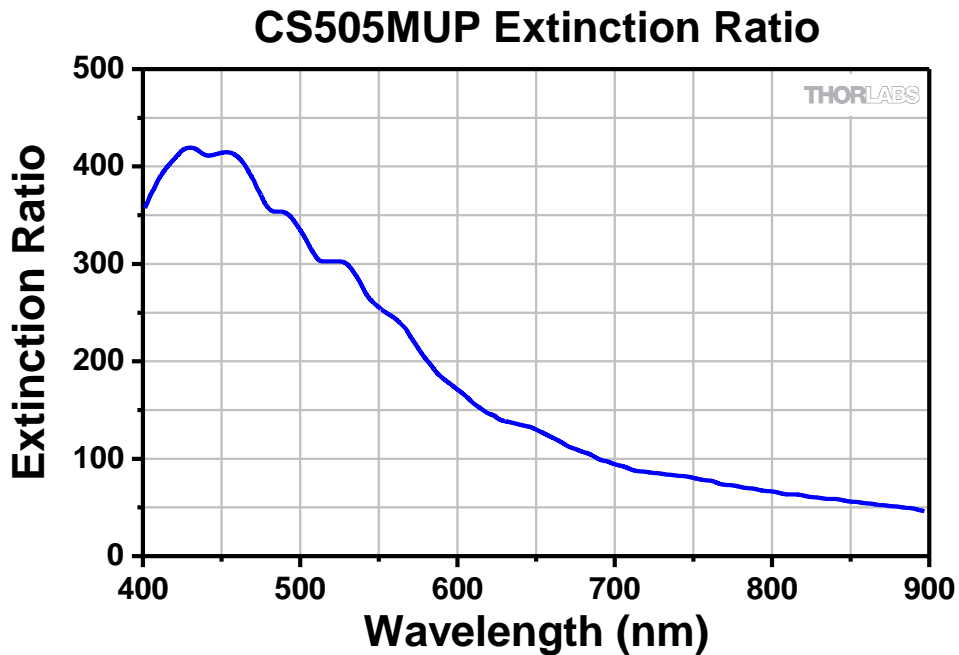

13.8. Micropolarizer Array

The CS505MUP image sensor incorporates an integral, linear micropolarizer array to detect the linear polarization states within the image. The micropolarizer array is fabricated directly on the sensor and arranged in a mosaic pattern as shown below. Each pixel is covered with one of four linear polarizers with orientations of -45° , 0° , 45° , or 90° . These pixel values are then used to compute the three polarization parameters for the light incident at every pixel; intensity, degree of linear polarization, and azimuth. Refer to the ThorCam user guide for more information on operating the polarization camera and interacting with polarization images.

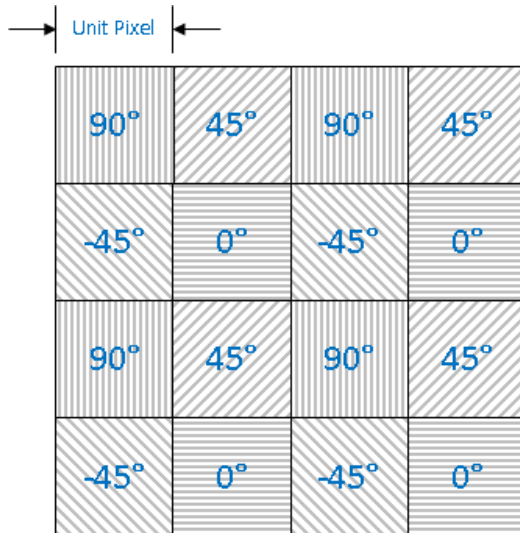

13.9. Polarization Azimuth Marking

Each CS505MUP comes with front plate marking that indicates the orientation of the incident polarization azimuth as interpreted by the software.



13.10. Software Compatibility

The CS505MUP camera will only work with ThorCam V3.3.0 or higher.

Chapter 14 CS895MU Specifications

14.1. CMOS Sensor Specifications

Sensor Specifications	
Sensor Type	CMOS Monochrome
Number of Active Pixels	4096 (H) x 2160 (V) (~8.9 MP)
Pixel Size	3.45 μm x 3.45 μm
Optical Format	1" Format (14131 μm x 7452 μm)
Peak Quantum Efficiency	72% Over 525 to 580 nm (Typical)
Dynamic Range	Up to 71 dB
Full Well Capacity	$\geq 10,650 e^-$
Shutter Type	Global

14.2. Quantum Efficiency

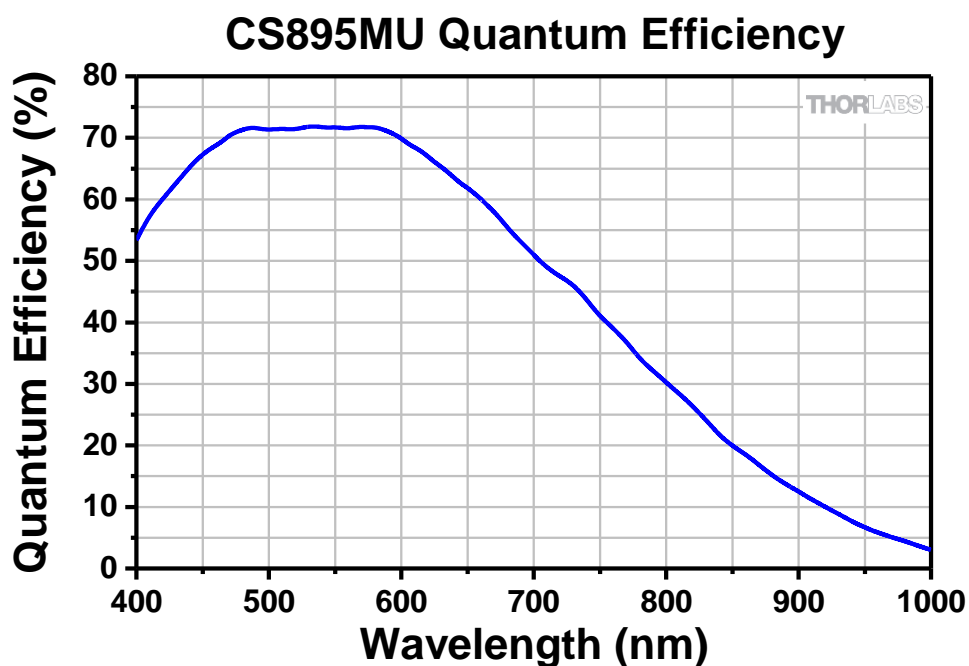

14.3. Imaging Specifications

Imaging Specifications	
Exposure Time	0.036 to 22795 ms in ~0.022 ms Increments
Pixel Clock Speed	198 MHz
ADC Resolution	12 Bits
Vertical and Horizontal Hardware Binning	1 x 1 to 16 x 16
Region of Interest (Width x Height) (For Binning 1 x 1)	260 x 4 Pixels to 4096 x 2160 Pixels, Rectangular
Read Noise	$< 2.5 e^-$ RMS
Overlapped Exposures	Frames per Trigger = Continuous Only

14.4. Example Frame Rates

ROI	Frame Rate
Full Sensor (4096 x 2160)	20.8 fps
Half Sensor (2048 x 1080)	40.8 fps
~1/10th Sensor (410 x 216)	175.4 fps
Min ROI (260 x 4)	922 fps

~1 ms Exposure Time, 1 x 1 Binning,
Frames per Trigger = Continuous

14.5. CS895MU Power Consumption

3.7 W Max @ 20.8 fps Full Sensor ROI

14.6. Operating/Storage Temperatures

Operating: 10 °C to 40 °C (Non-condensing)

Storage: 0 °C to 55 °C

Chapter 15 CS895CU Specifications

15.1. CMOS Sensor Specifications

Sensor Specifications	
Sensor Type	CMOS Color
Number of Active Pixels	4096 (H) x 2160 (V) (~8.9 MP)
Pixel Size	3.45 μm x 3.45 μm
Optical Format	1" Format (14131 μm x 7452 μm)
Dynamic Range	Up to 71 dB
Full Well Capacity	$\geq 10,650 e^-$
Shutter Type	Global

15.2. Quantum Efficiency

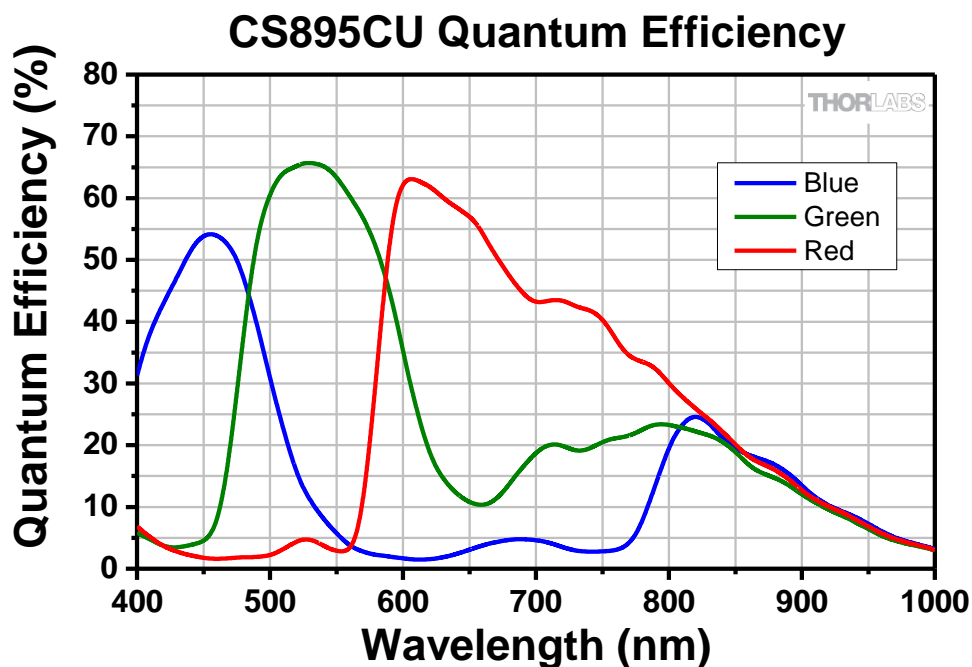

An IR-blocking filter is typically installed. This filter may be removed if NIR responsivity is desired. See Chapter 16 for specifications related to the IR-blocking filter. The Responsivity plot above is without an IR-blocking filter.

15.3. Imaging Specifications

Imaging Specifications	
Exposure Time	0.036 to 22795 ms in ~0.022 ms Increments
Pixel Clock Speed	198 MHz
ADC Resolution	12 Bits
Vertical and Horizontal Hardware Binning ¹	1 x 1 to 16 x 16
Region of Interest (Width x Height) (For Binning at 1 x 1)	260 x 4 Pixels to 4096 x 2160 Pixels, Rectangular
Read Noise	<2.5 e^- RMS
Overlapped Exposures	Frames per Trigger = Continuous Only

¹ – Binning >1 x 1 only available when operating camera in unprocessed mode (monochrome).

15.4. Example Frame Rates

ROI	Frame Rate
Full Sensor (4096 x 2160)	20.8 fps
Half Sensor (2048 x 1080)	40.8 fps
~1/10th Sensor (410 x 216)	175.4 fps
Min ROI (260 x 4)	922 fps

~1 ms Exposure Time, 1 x 1 Binning,
Frames per Trigger = Continuous

15.5. CS895CU Power Consumption

3.7 W Max @ 20.8 fps Full Sensor ROI

15.6. Operating/Storage Temperatures

Operating: 10 °C to 40 °C (Non-condensing)

Storage: 0 °C to 55 °C

Chapter 16 Protective Glass Windows

The protective glass window may be either an AR (anti-reflective) coated window for monochrome cameras, or an IR Filter for color cameras.

16.1. Protective Glass Window Dimensions

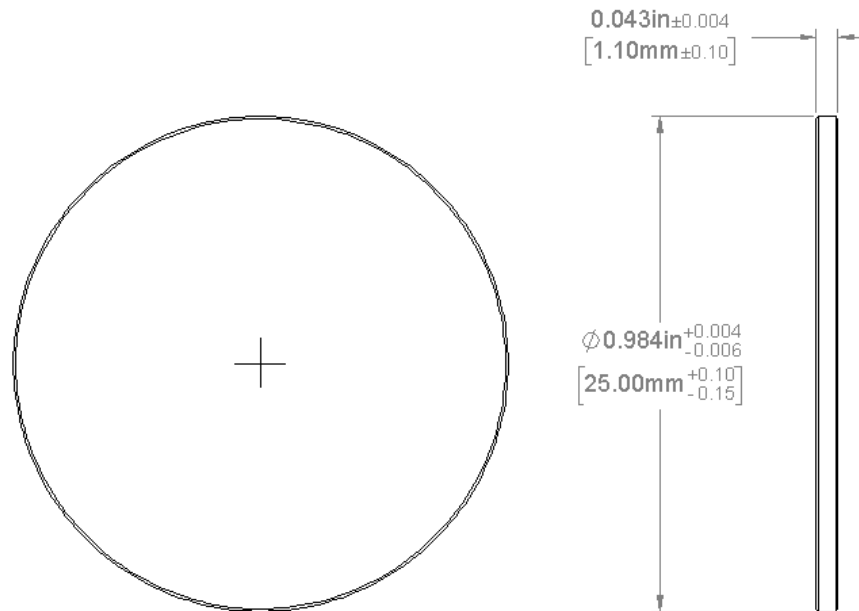

Figure 17 Protective Window Dimensions

16.2. AR-Coated Window Specifications

The AR coating has $R_{\text{avg}} < 0.5\%$ per surface over the 400 – 700 nm wavelength range.

16.3. IR Filter Transmission Curve

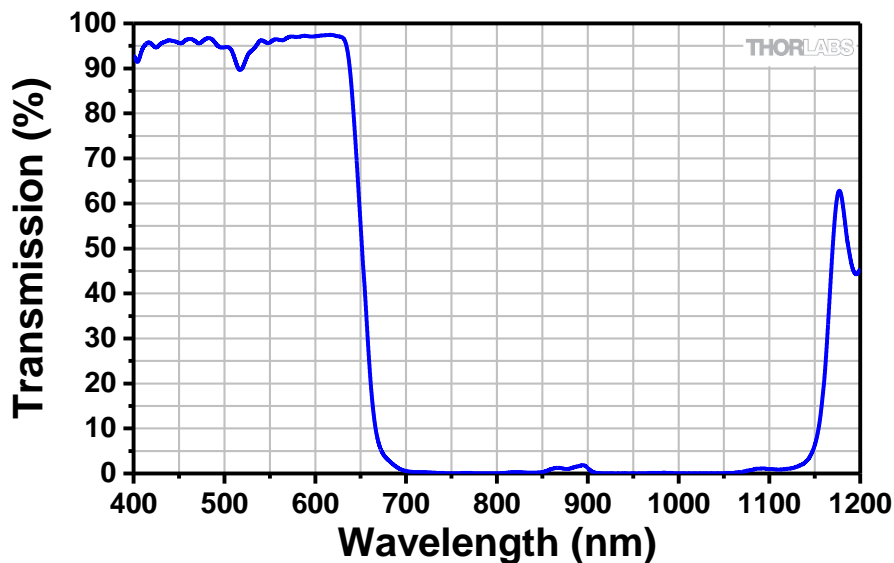

Figure 18 IR Blocking Filter Transmission Curve

Chapter 17 Mechanical Drawings

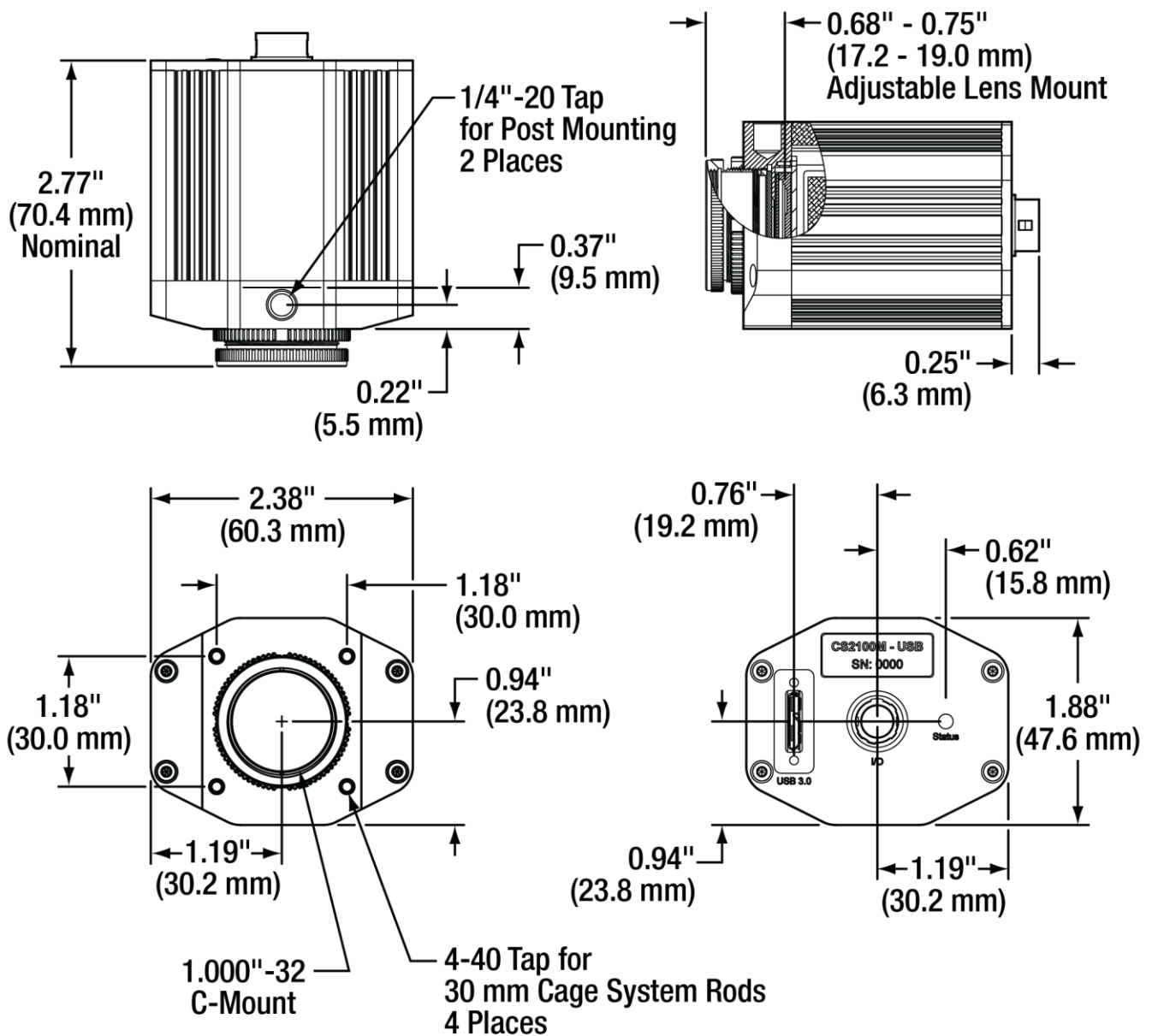

Figure 19 Compact Scientific Camera Dimensions

Chapter 18 Troubleshooting

18.1. Interface

Problem	Symptoms	Possible Cause	Remedy
Software cannot find a connected camera	<ul style="list-style-type: none"> Software does not display a connected camera. Software does not display an image. 	1. No power to camera.	1. Connect camera to USB 3.0 Port.
		2. Camera has yet to complete "enumeration".	2. Restart/refresh software after camera has been powered on and connected to host PC for at least 30 seconds.
		3. USB 3.0 camera not connected to USB 3.0 Port or has not enumerated properly.	3. See Section 4.1. Disconnect USB 3.0 cable and then reconnect. First time connections to a PC may take longer to enumerate and load drivers.

18.2. Optical

Problem	Symptoms	Possible Cause	Remedy
When using a standard C-mount lens (not included), the image is not in focus	<ul style="list-style-type: none"> Displayed image is not in focus. 	Back focus of camera needs to be set.	See Section 3.6.2 on how to set the camera's back focus.
Displayed image has spots or has debris in the image	<ul style="list-style-type: none"> Debris in the displayed image. 	IR filter has particulates on it.	Carefully clean IR filter. See Section 3.6 and Section 19.1.
"C-mount" detaches from camera after removing from Microscope	<ul style="list-style-type: none"> Threaded "C-mount" assembly remains on microscope. 	Lock nut not sufficiently tight.	See Section 3.6.

18.3. Operational

Problem	Symptoms	Possible Cause	Remedy
Camera excessively warm (too hot to safely hold with ungloved hand)	<ul style="list-style-type: none"> Camera is too hot to hold with an ungloved hand. Poor image quality. 	1. Camera is not properly ventilated.	1. Remove any obstructions or provide adequate ventilation around camera.
		2. Electronics failure.	2. Disconnect camera from USB3 port and contact customer service.
Imaging Software “times out” without acquiring image	<ul style="list-style-type: none"> Imaging software indicates timeout. No images acquired – no frame count provided. 	1. Camera is not powered.	1. See Section 18.1 Troubleshooting above.
		2. Camera is not connected to computer.	2. See Section 18.1 Troubleshooting above.
		3. Imaging software is not configured to camera.	3. Consult the ThorCam User Guide.
		4. Camera is not “armed” and “started” properly.	4. Refer to Section 4.1.
Low Bandwidth USB 3.0 connection	<ul style="list-style-type: none"> Excessive dropped frames Inconsistent operation 	1. Low bandwidth USB 3.0 port.	1.a. Use a PCIe high bandwidth USB 3.0 Card, such as: Thorlabs’ USB3-PCIE. 1.b. Use a different USB 3.0 port, preferably one directly connected to the motherboard.
		2. USB 3.0 cable is too long or poor quality.	2.a. Use the 3 m cable supplied with the camera. 2.b Use a 3 m (max) cable with 26AWG signal wires - or a 1m cable.
Yellow Indicator	<ul style="list-style-type: none"> Camera does not connect to Host 	1. Windows power saving settings.	1. Turn off all USB3.0 power saving settings in Device Manager.

18.4. Software

Problem	Symptoms	Possible Cause	Remedy
Camera not found	<ul style="list-style-type: none"> Error message, or camera does not show up in Hardware Connections. 	1. Power not on.	1. Make sure camera is connected to USB3 Port.
		2. Not plugged in.	2. Make sure camera is connected to USB3 Port.
		3. Bad USB cable or connection.	3. Try a different cable. Refer to Section 4.1 for information on the camera’s status indicators.
Insufficient illumination	<ul style="list-style-type: none"> Images are all black. 	1. Exposure time too low.	1. Make sure that exposure time is greater than 0; if the exposure is already greater than 0, try increasing the exposure time or gain gradually.
		2. No light going to the camera.	2. Make sure that the light source is turned on, and that the aperture of the lens (or other optics) is not shut.
		3. Lens Cap is Installed.	3. Remove Lens Cap.

Chapter 19 Maintenance

There are no user-serviceable parts inside the camera. Removing the rear cover of the camera without expressed authorization from Thorlabs will void the camera warranty.

Thorlabs scientific grade cameras are manufactured in a clean environment. Before shipping, each camera is tested to ensure that it meets stringent specifications for cleanliness and quality.

19.1. Cleaning Guidelines

Frequent lens changes, especially without careful attention to contaminants, can allow debris to accumulate on the infra-red blocking filter and lens surfaces. Therefore, Thorlabs provides the following guidelines for cleaning those components.

To minimize the need to clean the optical surfaces, do not remove the protective lens mount cap shipped with the camera until you are ready to mount the camera to the optical system.

For an informative tutorial refer to the [“Handling and Cleaning Procedures for Optical Components”](#). The following guidelines, specific to Thorlabs cameras, are meant to be used in conjunction with the procedures described in the tutorial.

Cleaning the Lens of Optical Assembly

Please follow the lens manufacturer’s recommendations for cleaning. Thorlabs is not responsible for any damage caused to a lens or optical assembly caused by customer cleaning or misuse.

To ensure optimum image quality with any Thorlabs camera, do not remove the protective lens-mount cap until ready to mount the camera on the application. If the camera is removed from the application, immediately replace the cap. Doing so will keep dust and other contaminants from accumulating on the optical surfaces. In addition, please note the following model-specific guidelines.

Standard Camera Precautions

While the lens mounting ring and locking flange allow the user some lens back-focus adjustment, complete removal of the ring will expose the sensor faceplate and will likely cause debris to accumulate on its surface. **Extreme care should be taken to avoid completely removing the lens mounting ring and exposing the sensor faceplate unless absolutely necessary. Fingerprints or other evidence of contact with the sensor faceplate may void the warranty.**

Cleaning the Infrared Filter or AR-Coated Window

The filter or window is visible when the lens is removed, mounted inside the lens mounting ring. This filter blocks invisible, near-infrared light from reaching the sensor. This is desirable in most applications where the camera is imaging in the visible spectrum.

- ***What must I do before cleaning the IR filter or AR-Coated Window?***

Do not remove the filter or window from the camera.

First, remove the lens and carefully examine the filter in a clean location under a strong, direct light. Try to determine if the contaminants are a few dust particles, oily smudge (such as fingerprints) or both.

- ***What if the contamination is only a few dust particles?***

Use a CLEAN, DRY (preferably brand-new), camel hair lens cleaning brush (such as those used by photographers) to gently wipe the particles off of the filter.

- **What if the contamination includes a smudge?**

1. Remove the camera from the optical assembly and bring the camera to a clean, dry location where it is safe to use flammable solvents (please see “Caution” below)
 - a. Carefully loosen the lens mount lock ring using the supplied lock ring wrench. Refer to Section 3.6.1.
2. Orient the camera so that the lens mount is pointing downward and carefully unscrew the lens mounting ring and integral filter.
3. Place the camera face down on a clean, dry surface to prevent particles from accumulating on the sensor’s faceplate.
4. Once the filter is removed, Use a CLEAN, DRY (preferably brand-new), camel hair lens cleaning brush (such as those used by photographers) to gently wipe the particles off of the filter.
5. Re-examine the filter after removing the dust. If a smudge is still visible, proceed by dipping a clean, lint-free cotton swab in ethyl or isopropyl alcohol. The swab should be saturated, but not dripping.
6. Carefully draw the swab once across the surface, then rotate the swab 180 degrees to expose the fresh surface and draw it across the filter surface again. Be careful not to pool alcohol on the glass surface.
7. Re-examine once again and repeat the process once, if necessary.

If contamination continues to be a problem, please call Thorlabs for assistance.

**CAUTION**

Ethyl and isopropyl alcohols are highly flammable! Do not use near extreme heat, arcing electrical equipment (such as space heaters) or open flame! Use only with proper ventilation. Follow all safety instructions provided by the manufacturer of the alcohol product.

Chapter 20 Regulatory

As required by the WEEE (Waste Electrical and Electronic Equipment Directive) of the European Community and the corresponding national laws, Thorlabs offers all end users in the EC the possibility to return “end of life” units without incurring disposal charges.

- This offer is valid for Thorlabs electrical and electronic equipment:
- Sold after August 13, 2005
- Marked correspondingly with the crossed out “wheelie bin” logo (see right)
- Sold to a company or institute within the EC
- Currently owned by a company or institute within the EC
- Still complete, not disassembled and not contaminated

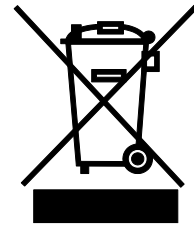

Wheelie Bin Logo

As the WEEE directive applies to self-contained operational electrical and electronic products, this end of life take back service does not refer to other Thorlabs products, such as:

- Pure OEM products, that means assemblies to be built into a unit by the user (e. g. OEM laser driver cards)
- Components
- Mechanics and optics
- Left over parts of units disassembled by the user (PCB's, housings etc.).

If you wish to return a Thorlabs unit for waste recovery, please contact Thorlabs or your nearest dealer for further information.

Waste Treatment is Your Own Responsibility



If you do not return an “end of life” unit to Thorlabs, you must hand it to a company specialized in waste recovery. Do not dispose of the unit in a litter bin or at a public waste disposal site.

Ecological Background

It is well known that WEEE pollutes the environment by releasing toxic products during decomposition. The aim of the European RoHS directive is to reduce the content of toxic substances in electronic products in the future.

The intent of the WEEE directive is to enforce the recycling of WEEE. A controlled recycling of end of life products will thereby avoid negative impacts on the environment.

20.1. Certifications and Compliance – CE Declaration of Conformity

		<h1>THORLABS</h1>	
		www.thorlabs.com	
<h2>EU Declaration of Conformity</h2> <p><i>in accordance with EN ISO 17050-1:2010</i></p>			
We:	Thorlabs Inc.		
Of:	56 Sparta Avenue, Newton, New Jersey, 07860, USA		
<i>in accordance with the following Directive(s):</i>			
2014/35/EU	Low Voltage Directive (LVD)		
2014/30/EU	Electromagnetic Compatibility (EMC) Directive		
2011/65/EU	Restriction of Use of Certain Hazardous Substances (RoHS)		
<i>hereby declare that:</i>			
Model:	CS2100M-USB, CS505MU, CS505CU, CS505MUP, CS895MU, CS895CU, CS235MU, CS235CU, CS135MU, CS135CU, CS135MUN		
Equipment:	Scientific Digital Camera with USB 3.0		
<i>is in conformity with the applicable requirements of the following documents:</i>			
EN 61010-1	Safety Requirements for Electrical Equipment for Measurement, Control and Laboratory Use.		2010
EN 61326-1	Electrical Equipment for Measurement, Control and Laboratory Use - EMC Requirements		2013
<i>and which, issued under the sole responsibility of Thorlabs, is in conformity with Directive 2011/65/EU of the European Parliament and of the Council of 8th June 2011 on the restriction of the use of certain hazardous substances in electrical and electronic equipment, for the reason stated below:</i>			
does not contain substances in excess of the maximum concentration values tolerated by weight in homogenous materials as listed in Annex II of the Directive			
<i>I hereby declare that the equipment named has been designed to comply with the relevant sections of the above referenced specifications, and complies with all applicable Essential Requirements of the Directives.</i>			
Signed:		On:	21 June 2017
Name:	Ann Strachan		
Position:	Compliance Manager	EDC - CS2100M-USB, CS505MU, CS505CU...	

20.2. FCC Statement

This device complies with part 15 of the FCC rules. Operation is subject to the following conditions: (1) This device may not cause harmful interference, and (2) this device must accept any interference received, including interference that may cause undesired operation.

This equipment has been tested and found to comply with the limits for a Class A digital device, pursuant to part 15 of the FCC Rules. These limits are designed to provide reasonable protection against harmful interference when the equipment is operated in a commercial environment. This equipment generates, uses, and can radiate radio frequency energy and, if not installed and used in accordance with the instruction manual, may cause harmful interference to radio communications. Operation of this equipment in a residential area is likely to cause harmful interference in which case the user will be required to correct the interference at their own expense.

Modifications not expressly approved by the manufacturer could void the user's authority to operate the equipment under FCC rules.

20.3. Auxiliary I/O Cable Requirements

The Digital Camera is not supplied with a cable for connecting to the AUX I/O port of the camera. This cable is application specific in all cases due to varying lengths and functions that are used. If an Auxiliary I/O cable is to be used with this camera it must be constructed with the requirements shown in Section 3.7.3 in order for the camera to adhere to CE and FCC compliance.

Chapter 21 Warranty

21.1. General Product Warranty

Thorlabs warrants that all products sold will be free from defects in material and workmanship, and will conform to the published specifications under normal use, when correctly installed and maintained.

21.2. Specific Warranties and Repairs

All specific warranty and repair information can be found in the general terms and conditions located at https://www.thorlabs.com/Images/PDF/LG-PO-001_Thorlabs_terms_and_%20agreements.pdf

Chapter 22 Thorlabs Worldwide Contacts

For technical support or sales inquiries, please visit us at www.thorlabs.com/contact for our most up-to-date contact information.



THORLABS

www.thorlabs.com
